



Cuscinetti assiali orientabili a rulli

Self-aligning thrust roller bearings



CUSCINETTI ASSIALI ORIENTABILI A RULLI

I cuscinetti ISB assiali orientabili a rulli (**Fig. 1**) sono realizzati in modo tale che il carico sia trasmesso da una pista all'altra secondo un certo angolo rispetto all'asse del cuscinetto.

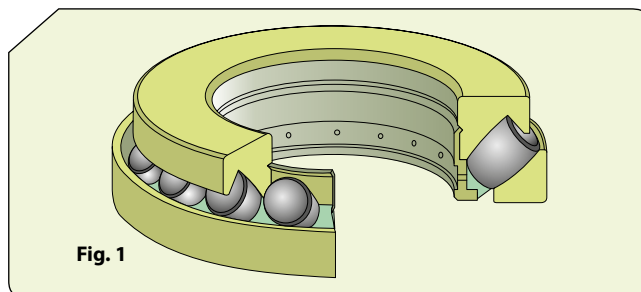

Fig. 1

Tale caratteristica fa sì che questi cuscinetti siano in grado di sopportare carichi assiali contemporaneamente a quelli radiali (**Fig. 2**); la loro orientabilità consente loro una certa adattabilità alle inflessioni dell'albero e ai disallineamenti di quest'ultimo rispetto all'alloggiamento.

I cuscinetti ISB assiali orientabili a sfere sono ideati a sopportare carichi assiali molto elevati in condizioni di esercizio; sono dotati di rulli sferici asimmetrici, e la progettazione delle loro piste permette un'ottima osculazione.

SELF-ALIGNING ROLLER THRUST BEARING

*ISB spherical roller thrust bearings (**Fig. 1**) are made in such a way that the load is transmitted from one raceway to another at a certain angle with respect to the bearing axis.*

*This feature means that these bearings are able to withstand axial loads at the same time as radial ones (**Fig. 2**); their adjustability allows them a certain adaptability to the deflections of the shaft and to the misalignments of the latter with respect to the housing.*

ISB self-aligning thrust ball bearings are suitable for withstanding very high axial loads under operating conditions; they are equipped with asymmetrical spherical rollers, and the design of their raceways allows excellent oscillation.

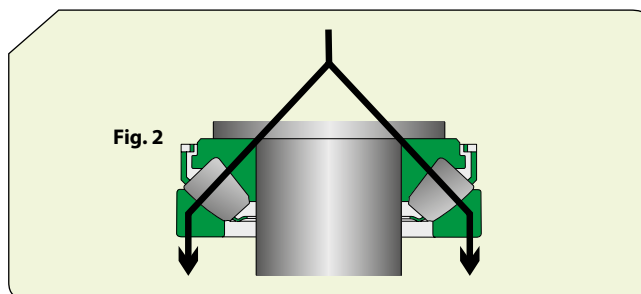

Fig. 2

Dimensioni

Le dimensioni di ingombro dei cuscinetti ISB assiali orientabili a rulli sono conformi alla norma ISO 104.

Tolleranze

I cuscinetti ISB assiali orientabili a rulli sono abitualmente prodotti con tolleranze normali, come indicato dalla norma ISO 199.

Disallineamento

Essendo orientabili, il disallineamento dell'albero rispetto all'alloggiamento e le inflessioni dell'albero stesso sono tollerati, entro certi limiti (**Fig. 3**); potere sfruttare appieno questo disallineamento dipende dal tipo di cuscinetto e dalla guarnizione.

Dimensions

The overall dimensions of ISB spherical roller thrust bearings comply with ISO 104 standard.

Tolerances

ISB spherical roller thrust bearings are usually produced with normal tolerances, as indicated by ISO 199 standard.

Misalignment

*Being orientable, the misalignment of the shaft with respect to the housing and the deflections of the shaft itself are tolerated, within certain limits (**Fig. 3**); the capacity to take full advantage of this misalignment depends on the type of bearing and seal.*

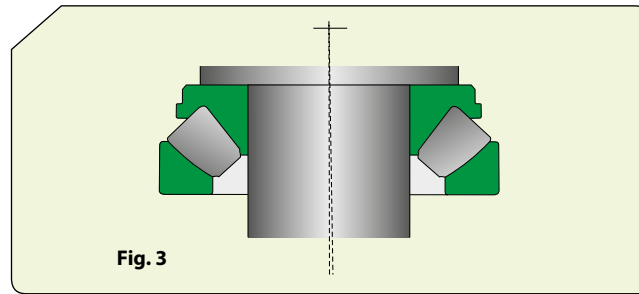

Fig. 3

Carico minimo

I cuscinetti ISB assiali orientabili a rulli devono essere soggetti ad un certo carico minimo, soprattutto se ruotano a velocità più elevate; in questo caso ed in presenza di rapidi cambi di direzione, le forze di inerzia di rulli e gabbie e l'attrito del lubrificante possono influire in modo negativo, provocando strisciamenti tra i rulli e le piste.

Appellativi supplementari

E	Esecuzione interna ottimizzata e gabbia stampata in acciaio del tipo a feritoie
EF	Esecuzione interna ottimizzata e gabbia massiccia in acciaio
EM	Esecuzione interna ottimizzata e gabbia massiccia in ottone
Y	Gabbia stampata in lamiera d'acciaio
M	Gabbia massiccia in ottone, a feritoia, centrata sui rulli

Minimum load

ISB spherical roller thrust bearings must be subjected to a certain minimum load, especially if they rotate at higher speeds; in this case and in the presence of rapid changes of direction, the inertia forces of rollers and cages and the friction of the lubricant can have a negative effect, causing sliding between the rollers and the raceways.

Additional suffixes

E	<i>Optimized internal execution and pressed steel cage of the slot-type</i>
EF	<i>Optimized internal execution and solid steel cage</i>
EM	<i>Optimized internal execution and solid brass cage</i>
Y	<i>Steel sheet molded cage</i>
M	<i>Solid brass cage, slot-type, centered on the rollers</i>

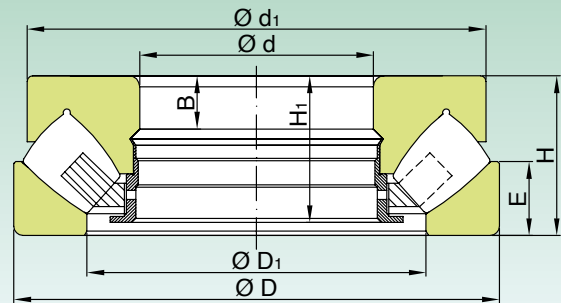
**CUSCINETTI ASSIALI ORIENTABILI A RULLI
SELF-ALIGNING THRUST ROLLER BEARINGS**

struttura fino a foro $\varnothing 100$
design up to bore $\varnothing 100$

Dimensioni (mm) Dimension (mm)								Coefficiente di carico (KN) Load rating (KN)		Velocità limite (giri/min) Speed limit (Rpm)		Peso (Kg) Weight (Kg)	Sigla Designation
d (mm)	D (mm)	H (mm)	D1 (mm)	B (mm)	H1 (mm)	E (mm)	d1 (mm)	Dinamico Dynamic C	Statico Static C ₀	Lubrificazione Lubrication			
										Grasso Grease	Olio Oil		
60	130	42	88	14.5	39	20	118	379	897	3825	2400	2.6	29412 M
65	140	45	96.5	16	42.1	21	128	440	1058	3672	2200	3.3	29413 M
70	150	48	102	17	44.1	23	137	505	1230	3290	2000	4.0	29414 M
75	160	51	109	18	48.4	24	146	587	1402	3060	2000	4.87	29415 M
80	170	54	116	19	49.5	26	155	651	1598	2907	1900	5.8	29416 M
85	180	58	125.2	20	55.3	28	164	717	1766	2754	1800	6.90	29417 M
90	155	39	117	13	37.1	19	148.50	392	1058	3060	3600	2.85	29318 M
	190	60	130	21	55.2	29	174	796	1969	2601	1700	8.10	29418 M
100	170	42	127.5	34		20.6	158.9	456	1264	2754	3240	3.8	29320 M
	210	67	142	54		31.5	189	960	2450	1200	1700	10.6	29420 M
110	190	48	142	37.5		23	176	598	1695	2448	2880	5.6	29322 M
	230	73	155.5	58		34.4	208	1156	2940	2142	2520	16.5	29422 M
120	210	54	156	42		25.9	193.5	749	2104	1100	1600	7.45	29324 M
	250	78	172	62.4		38	220	1345	3381	900	1300	17	29424 M
130	225	58	168	44		27.8	206.7	847	2449	1989	2340	9.3	29326 M
	270	85	185	63		41	248	1529	3969	1836	2160	22	29426 M
140	240	60	183	46		28	221	955	2793	950	1400	10.7	29328 M
	280	85	197.5	64		42	252	1600	4234	850	1200	24.6	29428 M
150	215	39	176	29		19	200.4	400	1568	2142	2520	4.3	29230 M
	250	60	190	47		29	228	981	2793	950	1400	11.2	29330 M
	300	90	214	70		44	275	1835	5069	800	1100	38.1	29430 M
160	270	67	205	53		31.7	249.6	1140	3405	850	1200	14.5	29332 M
	320	95	220.5	73		46.4	290	2038	5488	1530	1800	34.5	29432 M
170	280	67	216	49.6		31.7	260.3	1176	3479	1683	1980	16	29334 M
	340	103	234	80		48.8	310	2310	6508	1454	1710	44	29434 M
180	250	42	208	31.8		21.8	237	485	1999	1989	2340	5.88	29236 M
	300	73	229	56		34.4	275	1401	4214	1530	1800	19.6	29336 M
	360	109	249.5	85		51.8	326	2571	7269	700	950	63.1	29436 M
190	320	78	240.5	59.5		38.6	298.3	1597	4655	1454	1710	24.5	29338 M
	380	115	263	89.5		54.2	345	2793	7840	1301	1530	60.8	29438 M
200	280	48	233.5	35.3		24.3	266	643	2597	1683	1980	8.9	29240 M
	340	85	259	64		39.1	314	1823	5390	1301	1530	30.3	29340 M
	400	122	278	95		57.5	363	3139	8886	1224	1440	69	29440 M
220	300	48	253	36.5		24.3	285	676	2940	1683	1980	9.45	29244 M
	360	85	277.5	64		40.7	336	1960	6174	1301	1530	33	29344 M
	420	122	298.5	95		57	383.8	3283	9457	1148	1350	73.9	29444 M

**CUSCINETTI ASSIALI ORIENTABILI A RULLI
SELF-ALIGNING THRUST ROLLER BEARINGS**

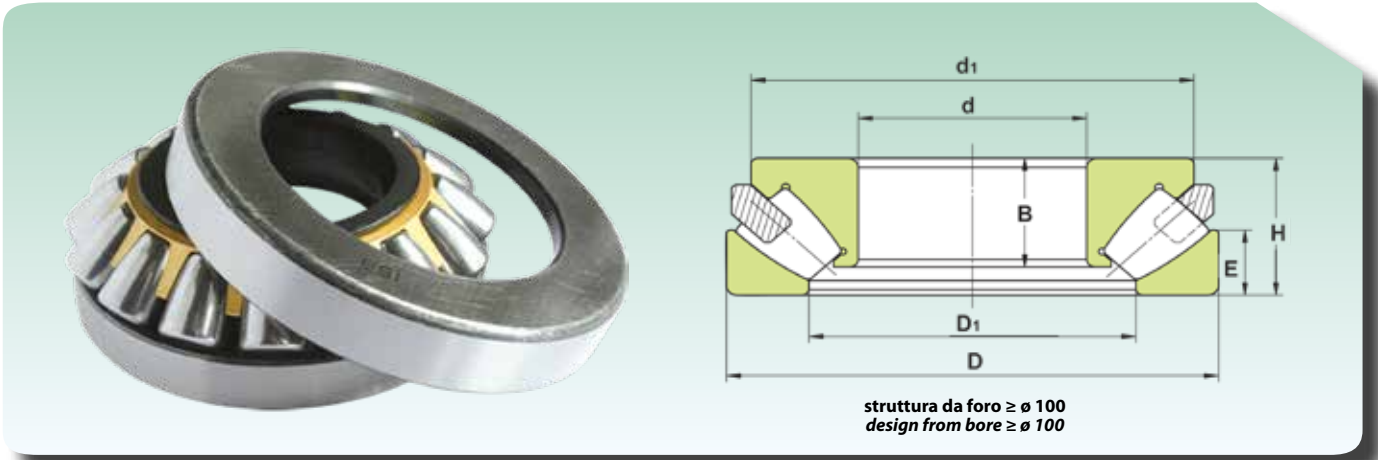

Dimensioni (mm) Dimension (mm)							Coefficiente di carico (KN) Load rating (KN)		Velocità limite (giri/min) Speed limit (Rpm)		Peso (Kg) Weight (Kg)	Sigla Designation
d (mm)	D (mm)	H (mm)	D1 (mm)	B (mm)	E (mm)	d1 (mm)	Dinamico Dynamic C	Statico Static C ₀	Lubrificazione Lubrication			
									Grasso Grease	Olio Oil		
240	340	60	281.5	46.4	29.6	324	783	3381	1377	1620	16.8	29248 M
	380	85	298.5	63	41.7	360	1990	6491	600	800	36	29348 M
	440	122	318.5	92.5	59.4	399	3318	10015	530	750	78	29448 M
260	360	60	302	46.2	29.8	343	801	3577	1301	1530	18	29252 M
	420	95	327.5	70	46	392.3	2499	8134	1071	1260	49.3	29352 M
	480	132	342	99	65	441	3925	12725	995	1170	102	29452 M
280	380	60	322.5	46.2	29.5	364	846	3920	700	1000	21.9	29256 M
	440	95	346	70	46.3	411	2499	8477	1071	1260	50.3	29356 M
	520	145	373.5	109.5	69	472	4802	14994	918	1080	131	29456 M
300	420	73	350.5	53	35.8	398.9	1049	4704	1071	1260	29.3	29260 M
	480	109	371.5	83	53	448	3005	10388	918	1080	72.5	29360 M
	540	145	395	109.9	68.3	494.4	4895	16385	450	650	138	29460 M
320	440	73	369.5	54	36	420	1088	4998	1071	1260	31.6	29264 M
	500	109	393	81.5	53	468	3283	10976	918	1080	75.4	29364 M
	580	155	420	116	75	534	5551	18620	842	990	174	29464 M
340	460	73	390	54	36	440	1107	5292	995	1170	33	29268 M
	540	122	428	40.6	117	59.5	2656	10780	842	990	105	29368 M
	620	170	449.5	128	80.1	560	6574	21952	765	900	211	29468 M
360	500	85	423	25	81	44	1431	6664	918	1080	52	29272 M
	560	122	442.5	90	58.1	523.3	2705	11368	480	650	111	29372 M
	640	170	470	126	81	588	6049	20776	727	855	224	29472 M
380	520	85	441	27	81	42	1548	7497	842	990	53	29276 M
	600	132	473	99.5	62.2	565	3273	13720	765	900	135	29376 M
	670	175	494	67	168	87.5	6682	23520	689	810	260	29476 M
400	540	85	460	62.5	42	514	1578	7840	842	990	61	29280 M
	620	132	489	100	64.7	582	3381	14308	727	855	154	29380 M
	710	185	529.5	138	86	652	7500	25970	650	765	298	29480 M
420	580	95	485	71	49.2	552.1	1950	9604	765	900	76	29284 M
	650	140	520	49	135	67.5	3665	15680	689	810	170	29384 M
	730	185	542.5	140	89.9	668	7645	26950	650	765	310	29484 M
440	600	95	508	30	91	46.5	2029	10192	765	900	78	29288 M
	680	145	540	49	140	70.5	5087	18914	650	765	180	29388 M
	780	206	583	150	97	716	8834	31360	574	675	407	29488 M
460	620	95	530	30	91	46	2029	10388	727	855	81	29292 M
	710	150	567	50	144	72.5	4224	18620	612	720	215	29392 M
	800	206	596	77	199	101.5	9125	32830	574	675	425	29492 M
480	650	103	556	33	99	53.5	2303	11564	689	810	98	29296 M
	730	150	582	112	74	684	4283	19208	612	720	212	29396 M
	850	224	625	88	216	108	9359	38220	513	603	550	29496 M

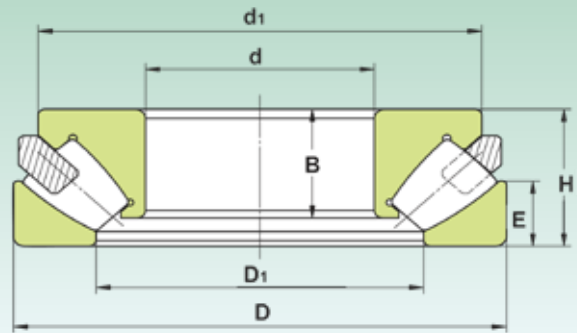
**CUSCINETTI ASSIALI ORIENTABILI A RULLI
SELF-ALIGNING THRUST ROLLER BEARINGS**

**struttura da foro $\geq \varnothing 100$
design from bore $\geq \varnothing 100$**

Dimensioni (mm) Dimension (mm)							Coefficiente di carico (KN) Load rating (KN)		Velocità limite (giri/min) Speed limit (Rpm)		Peso (Kg) Weight (Kg)	Sigla Designation
d (mm)	D (mm)	H (mm)	D1 (mm)	B (mm)	E (mm)	d1 (mm)	Dinamico Dynamic C	Statico Static C ₀	Lubrificazione Lubrication			
									Grasso Grease	Olio Oil		
500	670	103	571.5	76	50.5	640.5	2342	12250	689	810	97.5	292/500 M
	750	150	611	50	144	74	4400	19992	612	720	235	293/500 M
	870	224	650	160	107	797	9183	39200	513	603	555	294/500 M
530	710	109	604	80	56	675	3048	14994	650	765	118	292/530 M
	800	160	648	53	154	76	5720	26200	574	675	270	293/530 M
	920	236	686	89	228	116	10290	43120	482	567	650	294/530 M
560	750	115	644	37	111	61	2930	15680	612	720	140	292/560 M
	980	250	727	99	241	122	11760	49980	428	504	810	294/560 M
600	800	122	687	90	58.9	770	3665	18228	536	630	161	292/600 M
	900	180	720	65	174	89	7379	33810	482	567	405	293/600 M
	1030	258	770.5	185	126	954.8	12838	54880	405	477	860	294/600 M
630	850	132	723	50	127	62	4675	23128	513	603	210	292/630 M
	950	190	761	68	183	92	8281	37240	459	540	485	293/630 M
	1090	280	815	107	270	137	14112	60760	383	450	1040	294/630 M
670	900	140	773	45	135	73	4116	22344	482	567	255	292/670 M
	1150	290	872	205	138	1054	15092	66640	344	405	1225	294/670 M
710	1060	212	855	74	205	103	9751	44590	383	450	660	293/710 M
	1220	308	917	117	298	149	17248	74970	329	387	1500	294/710 M
750	1000	150	858	50	144	74	5978	30380	428	504	325	292/750 M
	1120	224	910	76	216	109	9183	44100	367	432	770	293/750 M
	1280	315	964	121	305	153	18326	83300	306	360	1650	294/750 M
800	1060	155	911	52	149	77	6429	33810	405	477	380	292/800 M
	1180	230	965	77	222	111	10910	54450	344	405	865	293/800 M
	1360	335	1034	123	324	165	19796	91140	275	324	2025	294/800 M
850	1120	160	967	47	154	82	6595	35280	383	450	425	292/850 M
	1440	354	1077	142	342	172	23422	105840	260	306	2390	294/850 M
900	1520	372	1137	147	360	186	26166	120500	230	270	2650	294/900 M
950	1250	180	1087	58	174	88	8114	44590	329	387	600	292/950 M
	1600	390	1209	153	377	191	27636	130290	214	252	3065	294/950 M
1000	1670	402	1270	155	389	190	30478	138101	199	234	3380	294/1000 M
1060	1400	206	1211	66	199	100	10290	57330	275	324	860	292/1060 M
	1770	426	1349	192	412	207	32732	154200	184	216	4280	294/1060 M
1180	1520	206	1331	83	199	101	10682	62720	260	306	950	292/1180 M
1250	1800	330	1474	148	319	161	24304	126420	184	216	2770	293/1250 M
1600	2280	408	1885	166	395	195	36064	196000	122	144	5375	293/1600 M