

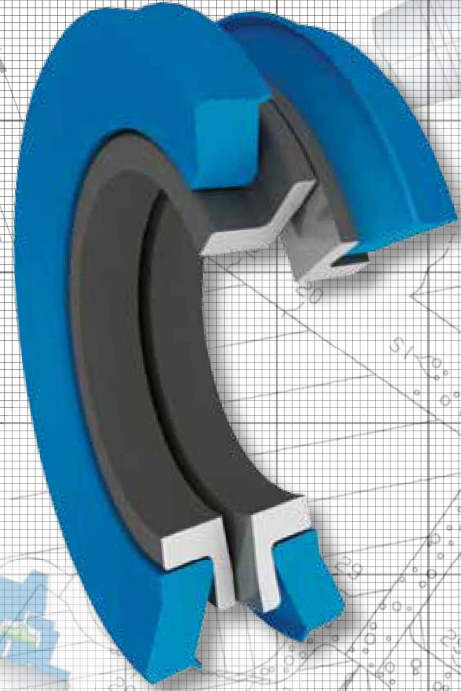

Tenute meccaniche frontali
Floating seals
Joint à glace

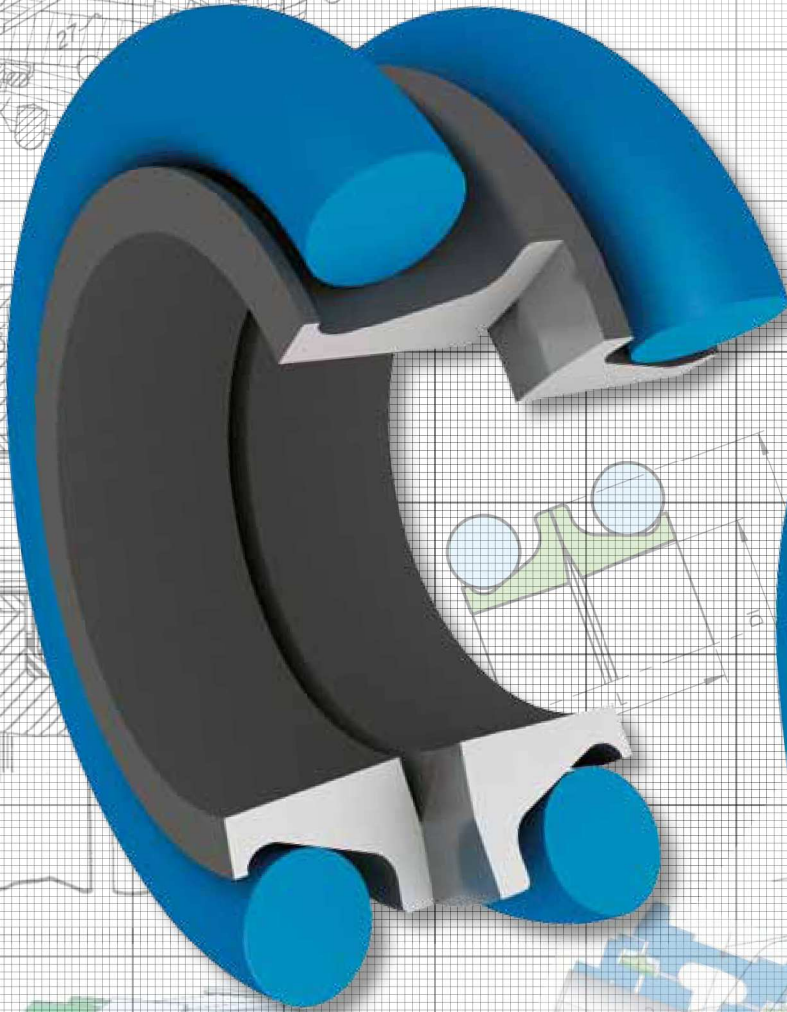
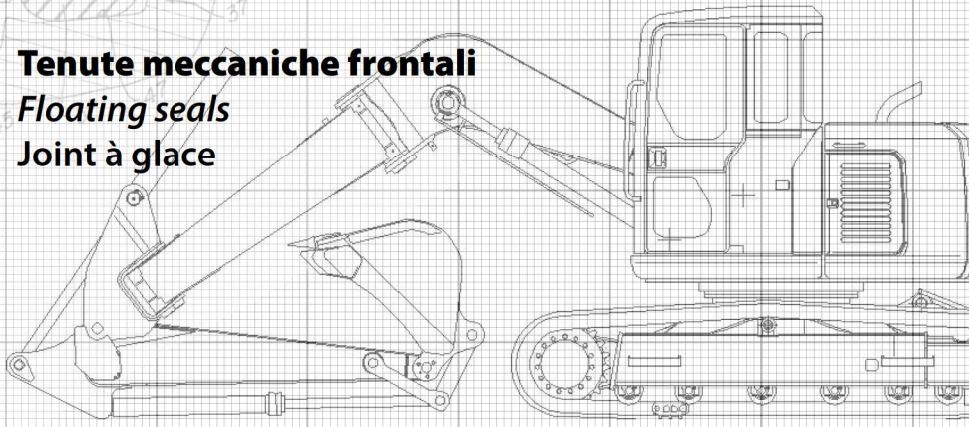

OT Seals S.r.l. - Via Pitagora, 1 - 42048 Rubiera (RE) ITALIA
Tel. 0039 0522 622711 - Fax 0039 0522 622707
CF e P.IVA 02755260961 - info@otseals.it - www.otseals.it

Sealing Technical Products

Gamma STANDARD

Standard range - Game standard

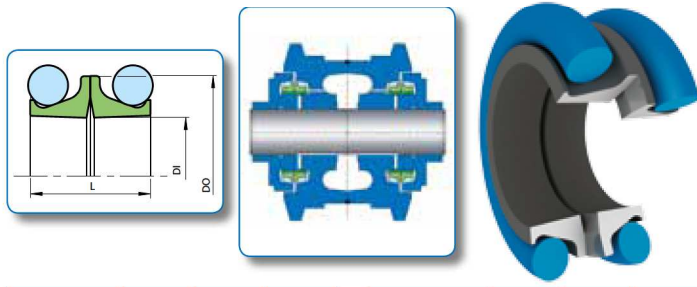

P/N	DI	DO	L
OFS03850621S	38,00	50,60	21,20
OFS04305824S	43,00	58,00	24,00
OFS04505821S	45,00	58,00	21,00
OFS04806224S	48,00	62,00	24,40
OFS05106527S	51,00	65,00	27,00
OFS05406824S	54,00	68,00	24,40
OFS05607025S	56,00	70,00	25,00
OFS05874329S	58,00	74,30	29,00
OFS63582532S	63,50	82,50	32,00
OFS06407825S	64,00	78,00	25,20
OFS68808424S	68,80	84,00	24,40
OFS71709029S	71,70	90,00	29,00
OFS07309232S	73,00	92,00	32,00
OFS73388320S	73,30	88,30	20,00
OFS73786821S	73,70	86,80	21,50
OFS07793329S	77,00	93,30	29,00
OFS77509216S	77,50	92,00	16,00
OFS08010029S	80,00	100,00	29,00
OFS90510932S	90,50	109,60	32,00
OFS09210922S	92,00	109,00	22,00
OFS93510722S	93,50	107,00	22,00
OFS09511432S	95,00	114,00	32,00
OFS10011932S	100,00	119,00	32,00
OFS10112030S	101,00	120,00	30,20
OFS10212233S	102,30	122,00	33,00
OFS10411721S	104,00	117,00	21,40
OFS10412123S	104,20	121,00	23,40
OFS10913232S	109,00	132,20	32,00
OFS11012832S	110,00	128,00	31,60
OFS11413731S	114,00	137,00	31,00
OFS11814030S	118,00	140,00	29,80
OFS12414122S	124,00	141,20	22,00
OFS12514432S	125,00	144,00	32,60
OFS12714531S	127,00	145,00	31,00
OFS13015132S	130,00	151,00	32,00
OFS13715331S	137,00	153,20	30,60
OFS14215625S	142,00	156,00	25,00
OFS14315725S	143,00	157,50	25,40
OFS14617238S	146,00	172,00	38,00
OFS14817032S	148,50	170,80	31,50
OFS15416826S	154,00	168,20	26,00
OFS16018032S	160,00	180,00	32,00
OFS16319138S	163,00	191,00	38,00
OFS16319146S	163,00	191,00	46,00
OFS17820038S	178,50	200,50	38,00

P/N	DI	DO	L
OFS18221038S	182,00	210,00	38,00
OFS18221046S	182,00	210,00	46,00
OFS19021646S	190,00	216,00	46,00
OFS19221534S	192,00	215,00	34,00
OFS20422630S	204,50	226,50	30,00
OFS20522730S	205,00	227,00	30,00
OFS20923442S	209,00	234,00	42,00
OFS22024636S	220,00	246,00	36,00
OFS22124125S	221,50	241,50	25,00
OFS22224636S	222,50	246,00	36,00
OFS22425138S	224,60	251,70	38,00
OFS22525240S	225,00	252,00	40,00
OFS22726038S	227,70	260,00	38,00
OFS23026036S	230,00	260,00	36,00
OFS23126039S	231,00	260,00	39,00
OFS23525834S	235,00	258,00	34,00
OFS23926842S	239,00	268,50	42,00
OFS24026742S	240,00	267,00	42,00
OFS25027243S	250,00	277,40	43,00
OFS25627936S	256,00	279,00	36,00
OFS26028840S	260,00	288,00	41,00
OFS26529338S	265,00	293,00	38,00
OFS26529346S	265,00	293,00	46,00
OFS27330038S	273,00	300,00	38,00
OFS27530338S	275,00	303,00	38,00
OFS27830940S	278,00	309,50	40,00
OFS29832842S	298,00	328,00	42,00
OFS31834638S	318,00	346,50	38,00
OFS31834638S	318,50	346,40	46,00
OFS31834746S	318,00	347,00	46,00
OFS33836840S	338,00	368,00	40,00
OFS35137538S	351,00	375,00	38,00
OFS35638138S	356,00	381,50	38,00
OFS36639438S	366,00	394,00	38,00
OFS38040540S	380,00	405,00	40,00
OFS38741538S	387,00	415,00	38,00
OFS42945738S	429,20	457,20	38,00
OFS43145638S	431,00	456,50	38,00
OFS46049042S	460,00	490,00	42,00
OFS50052643S	500,00	527,00	43,40
OFS5055344S	505,00	533,40	44,00
OFS50653444S	506,00	534,00	44,00
OFS50854860S	508,00	548,00	60,00
OFS66670044S	666,70	700,00	44,00

Gamma L

L range - Game L

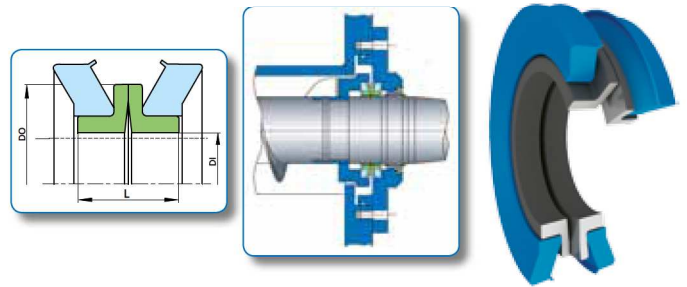

P/N	DI	DO	L
OFS04205920L	42,00	59,00	20,00
OFS04706220L	47,00	62,00	20,00
OFS05006520L	50,50	65,00	20,00
OFS05407322L	54,00	73,00	22,00
OFS05807319L	58,00	73,00	19,00
OFS05858020L	58,50	80,00	20,00
OFS05808020L	58,60	80,00	20,00
OFS05877820L	58,70	78,00	20,00
OFS06358119L	63,50	81,00	19,00
OFS06786220L	67,00	86,20	20,00
OFS06886220L	68,00	86,20	20,00
OFS73892820L	73,80	92,80	20,00
OFS07409920L	74,00	99,00	20,00
OFS07709724L	77,00	97,00	24,00
OFS81710120L	81,70	101,50	20,00
OFS82510022L	82,50	100,00	22,00
OFS87511119L	87,50	111,50	19,00
OFS09010627L	90,00	106,00	27,00
OFS09110921L	91,00	109,00	21,00
OFS09211324L	92,00	113,00	24,00
OFS09411224L	94,00	112,50	24,00
OFS09912320L	99,00	123,00	20,00
OFS10212221L	102,00	122,00	21,00
OFS10412624L	104,00	126,00	24,00
OFS10512424L	105,00	124,00	24,00
OFS11413326L	114,00	133,20	26,00

P/N	DI	DO	L
OFS12414432L	124,00	144,00	32,00
OFS12614428L	126,50	144,20	28,00
OFS12714427L	127,00	144,80	27,00
OFS13315628L	133,00	156,00	28,00
OFS14816832L	148,50	168,00	32,40
OFS15017530L	150,00	175,00	30,00
OFS15418036L	154,00	180,00	36,00
OFS15517934L	155,00	179,80	34,00
OFS15818018L	158,00	180,00	18,00
OFS16919533L	169,00	195,00	33,00
OFS19321434L	193,00	214,30	34,00
OFS19822435L	198,00	224,00	35,00
OFS22726041L	227,60	260,50	41,44
OFS22826041L	228,00	260,50	41,00
OFS23325935L	233,00	259,00	35,00
OFS24127336L	241,00	273,50	36,60
OFS24727042L	247,00	270,00	42,00
OFS28331334L	283,00	313,00	34,00
OFS28332342L	283,50	323,00	42,00
OFS32035240L	320,00	352,50	40,00
OFS35539239L	355,00	392,00	39,60
OFS44247038L	442,00	470,00	38,00
OFS49253043L	492,00	530,00	43,00

Materiali anello di tenuta

Shaft seal materials - Matériaux bagues d'étanchéité

Standard Acciaio al Cromo-Molibdeno 100 Cr6 secondo UNI 3097

Standard chrome molybdenum steel 100 Cr6 UNI 3097

Standard acier Chrome Molybdène 100 Cr6 selon UNI 3097

Specifiche di finitura Finishing specifications Surface de finition	Durezza Hardness Dureté	Lappatura Lapping Rodage	Planarità Planarity Planarité	
100Cr6	HRC65/72	0,015 micron	1 micron	
Materiali alternativi Alternative materials Matériaux alternatifs	Processo Process Processus	Costo Cost Cout	Durata Durability Durée	Resistenza alla corrosione Corrosion resistance Résistance à la corrosion
C6 lega Ni-alloy C6 Ni-Alloy C6 alliage Ni-alloy	Fusione Melting Fusion	Alto High Haute	Alta High Haute	Alta High Haute
STELLITE Fe-alloy STELLITE Fe-Alloy Stellite Fe-alloy	Fusione Melting Fusion	Medio Midum Moyenne	Media Midum Moyenne	Alta High Haute
SAE 1074	Stampaggio Molding Moulage	Basso Low Bas	Bassa Low Basse	Bassa Low Basse
SAE 52100	Forgiatura Forging Forgeage	Basso Low Bas	Bassa Low Basse	Bassa Low Basse

Materiali anello di spinta

Thrust ring materials - Matériaux bagues de butée

Standard gomma sintetica nitrilica NBR 70 ShA

Standard synthetic nitrile rubber NBR 70 ShA

Standard caoutchouc synthétique nitrile NBR 70 ShA

Specifiche di finitura Finishing specifications Surface de finition	Limiti temperatura °C Temperature limits °C Limites de températures °C	Durezza Hardness Dureté	Superficie Surface Surfaces
NBR	-40/110	70 ShA	Liscia Smooth Lisse
Materiali alternativi Alternative materials Matériaux alternatifs	Limiti temperatura °C Temperature limits °C Limites de températures °C	Resistenza all'abrasione Abrasion resistance Résistance à l'abrasion	Costo Cost Cout
HNBR	-50/135	Ottima Excellent Haut	Medio Medium Moyenne
SILICONE SILICONE SILICONE	60/165	Scarsa Low Bas	Medio Medium Moyenne
VITON	-10/190	Buona Good Bonne	Alto High Haute

Per ulteriori informazioni, potete richiedere il Catalogo Tecnico, disponibile anche online: www.otseals.it

For further information, please ask for the Technical Catalogue, also available online: www.otseals.it

Pour ultérieures informations, veuillez nous demander notre Catalogue Technique, disponible même sur internet: www.otseals.it