

## 1. Caratteristiche boccole SF-1

## 1. SF-1 bushings characteristics

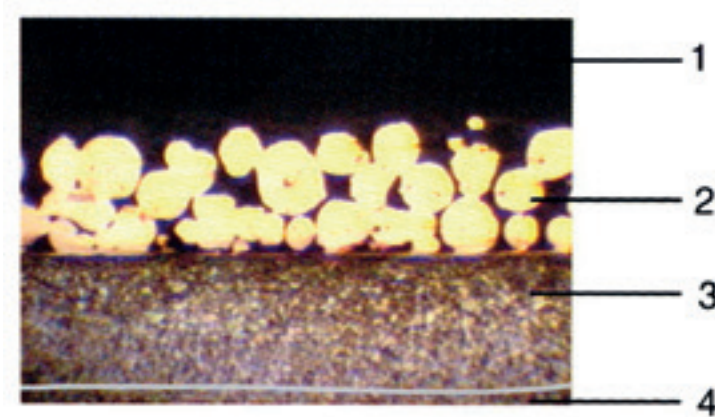

1. PTFE <i>PTFE</i>	0,01 ~ 0,03 mm
2. Bronzo poroso <i>Porous bronze</i>	0,2 ~ 0,30 mm
3. Armatura d'acciaio <i>Steel backing</i>	0,70 ~ 2,30 mm
4. Stagnatura <i>Tin plating</i>	~ 0,005 mm
Ramatura <i>Copper-plating</i>	~ 0,008 mm

### 1.1 Caratteristiche e funzionalità

Le boccole SF-1 presentano molteplici caratteristiche che si possono così riassumere:

- esenti da lubrificazione
- elevata capacità di carico - 140 N/mm<sup>2</sup> - grazie alla distribuzione del carico su ampie superfici elasto-plastiche
- elevata scorrevolezza e basso coefficiente d'attrito sia statico sia dinamico (nessun effetto stick-slip)
- temperatura d'esercizio da -195 °C a +250 °C
- vibrazioni, rumore ed inquinamento ridottissimi. Possibilità di utilizzare metalli di accoppiamento a bassa durezza facilitandone la lavorazione e riducendone i costi
- materiale leggero, compatto e con minimi ingombri
- facilità di montaggio
- non assorbono olio o acqua, presentano una bassa espansione ed un'alta conducibilità nonché una buona stabilità termica
- elevata resistenza chimica: possono essere ricoperti o placcati con materiali resistenti a liquidi, gas o solidi chimicamente aggressivi attraverso uno strato galvanico supplementare.

### 1.1 Functionality and characteristics

The SF-1 bushings present multiple characteristics which can be summarized as follows:

- *exempt from lubrication*
- *elevated load capacities - 140 N/mm<sup>2</sup> - on large elasto-plastic surfaces*
- *elevated flow and low friction coefficients both static and dynamic (no stick-slip effect)*
- *the exercising temperature is from -195 °C to +250 °C.*
- *vibration, noise and pollution maximally reduced. The possibility to use coupling metals which have low hardness facilitating the work and reducing costs*
- *light weight materials, compact and with minimum encumbrance*
- *ease of mounting*
- *oil or water are not absorbed, presenting low expansion, high conductivity and excellent thermal stability*
- *elevated chemical resistance: easily covered with materials resistant to liquid, gas or solids which are chemically aggressive using a supplementary galvanic layer.*

### 1.2 Utilizzo

Le boccole SF-1 trovano largo impiego nei veicoli idraulici, automobili, motociclette, macchine agricole, macchine tessili, macchine per la stampa, attrezzature ginniche e molte altre applicazioni.

Le boccole SF-1 hanno solitamente un buon adattamento iniziale (rodaggio) con un usura di 0,01 ~ 0,02 mm.

Durante la fase di rodaggio una parte della superficie in PTFE si deposita sull'albero o sulla superficie di strisciamento (fig. 1) formando così un film autolubrificante in grado di ridurre l'attrito e l'usura.

Dopo questa fase iniziale e con il progressivo aumento delle ore di funzionamento, al raggiungimento dell'80% di consumo di PTFE, si considera la boccia esaurita e quindi da sostituire.

La rugosità di superficie deve essere solitamente inferiore a 0,8 µ. La curva tipica di usura viene mostrata nella fig. 2.

### 1.2 Use

SF-1 bushings are widely used in hydraulic vehicles, automobiles, motorcycles, agricultural machines, textile machines, printing machines, gymnastic equipment and many other applications.

SF-1 bushings generally have good initial adaptability with a wear of 0,01 ~ 0,02mm.

During the adjustment period a part of the surface in PTFE is deposited on the shaft or on the contact surface (fig. 1) forming a self-lubricating film capable of reducing friction and wear.

After this initial phase and with progressive increases in the functioning hours, once 80% of the PTFE is consumed, the bushing is considered depleted and therefore should be replaced.

The roughness of the surface must generally be inferior to 0,8 µ. The typical wear curve is shown in fig. 2.

**Usura di rodaggio - Wear trial**

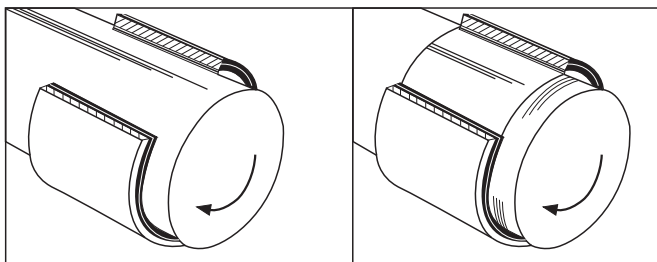

prima del rodaggio  
before trial

dopo il rodaggio  
after trial

Fig. 1

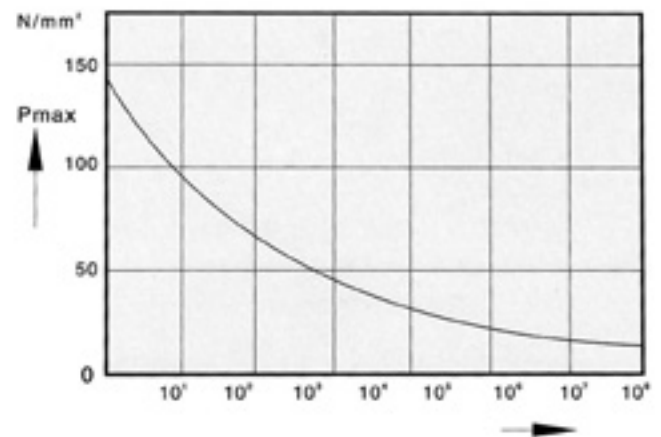

Fig. 2

### 1.3 Capacità di carico

La capacità di carico delle boccole è espressa attraverso il fattore di carico  $Pv$  ( $N/mm^2 \cdot m/s$ ) dove  $P$  rappresenta il carico specifico e  $v$  la velocità. Il carico specifico massimo applicabile in condizioni costanti può raggiungere il valore di  $140 N/mm^2$ , mentre in condizioni dinamiche, quindi con movimenti rotatori ed oscillanti, il limite del carico specifico può scendere a  $56 N/mm^2$ .

La capacità di carico può essere influenzata dalla temperatura: è importante quindi mantenerla costante per ottenere le migliori prestazioni aumentando così la durata della boccola.

Se consideriamo  $F$  come carico totale,  $d$  il diametro interno e  $b$  la lunghezza, il limite del carico equivale a:

$$p = \frac{F}{d \cdot b}$$

Anche la lubrificazione può influenzare il fattore di carico, infatti il carico specifico  $p$  massimo ammissibile dipende dalle condizioni di ingrassaggio come riportato nella fig. 3.

### 1.3 Load capacity

The load capacity of the bushing is expressed using the load factor  $Pv$  ( $N/mm^2 \cdot m/s$ ) where  $P$  represents the specific load and  $v$  the velocity. The specific maximum load applicable in constant conditions can reach a value of ( $140 N/mm^2$ ), while in dynamic conditions, therefore with rotary and oscillating movement, the specific load limit can decrease to  $56 N/mm^2$ . The limit of the load can be influenced by the temperature: it is important to maintain constant temperature in order to obtain the best performances and therefore to increase the duration of the bushing.

If we consider  $F$  as total load,  $d$  the internal diameter and  $b$  the length, the load limit will be equal to:

The lubrication can influence the load factor too: in fact the maximum specific load  $p$  depends on the conditions of the greasing, as shown in fig. 3.

Fattore  $Pv$  con e senza lubrificazione -  $Pv$  factor with dry and lubricating condition

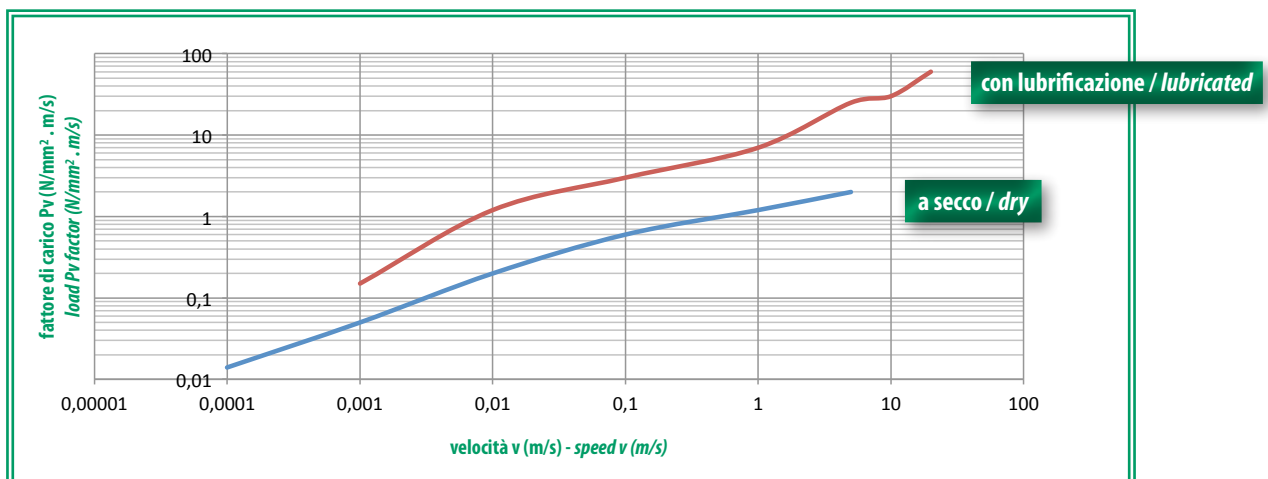

Fig. 3

### 1.4 Fluidi lubrificanti

Sebbene il materiale utilizzato per la costruzione del SF-1 sia di buona qualità ed utilizzabile a secco, qualora fosse impiegato in presenza di fluidi, liquidi e/o lubrificanti il limite Pv aumenterebbe sensibilmente; infatti la presenza di fluidi rende possibile lo smaltimento del calore d'attrito ed il contatto tra le superfici, aumentando la durata utile della boccia. La presenza di fluidi lubrificanti crea le condizioni adatte per il funzionamento idrodinamico, incrementando notevolmente la velocità di strisciamento a parità di carico specifico p. È opportuno verificare sempre la compatibilità della boccia, con il fluido presente, in quanto potrebbero verificarsi situazioni di controindicazione nell'utilizzo di un fluido piuttosto che un altro.

È consigliabile provare ad immergere metà boccia nel fluido per circa due settimane e verificare che la boccia risulti inalterata in ogni sua parte.

### 1.5 Temperatura

Nel caso in cui la temperatura rimanga tra 0 °C e 100 °C, l'impatto sul coefficiente d'attrito è piuttosto limitato; qualora superasse questo limite, il coefficiente d'attrito aumenterebbe rapidamente all'incirca del 50%. Con una temperatura stimata oltre i 200 °C ed a parità di fattore di carico, la durata della boccia si ridurrebbe dell'80% rispetto a quella registrata a 20 °C (tabella 1).

### 1.4 Lubricants fluids

*Despite the material used for the construction of the SF-1 is of good quality and usable when dry, when used in the presence of fluids, liquids and or lubricants the limits Pv increase sensibly; in fact, the presence of fluids allows the dispersion of the friction heat possible and the contact between the surfaces, increasing the useful duration of the bushing. The presence of lubricating fluids creates the adapt conditions for the hydrodynamic functioning, incrementing noticeably the sliding velocity bling the specific load the seme. It is worthwhile to always verify the compatibility of the bushing with the fluid present because an undesirable effect could be experienced in the use of one fluid rather than another.*

*It is advisable to try to immerge hall of the bushing in the fluid for approximately 2 weeks to verify that the bushing remains unchanged in every part.*

### 1.5 Temperature

*In case the temperature remains between 0 °C and 100 °C, the impact of the friction coefficient is rather limited; once this limit is surpassed, the friction coefficient increases rapidly by approximately 50%. With an estimated temperature of over 200 °C and with costant load factor, the duration of the bushing would be reduced by 80% with respect to that registered at 20 °C (table 1).*

Velocità (m/s) Speed (m/s)	Carico (N/mm <sup>2</sup> ) Load (N/mm <sup>2</sup> )	Limite - Temperatura fattore Pv - Limit Pv at various temperature		
		Limite Pv (N/mm <sup>2</sup> · m/s) - Pv Limit (N/mm <sup>2</sup> · m/s)		
		20 °C	100 °C	200 °C
<b>0,0001</b>	<b>140</b>	<b>0,014</b>	<b>0,014</b>	<b>0,014</b>
<b>0,001</b>	<b>50</b>	<b>0,5</b>	<b>0,3</b>	<b>0,1</b>
<b>0,01</b>	<b>6</b>	<b>0,6</b>	<b>0,35</b>	<b>0,12</b>
<b>1,0</b>	<b>1,2</b>	<b>1,2</b>	<b>0,72</b>	<b>0,24</b>
<b>5,0</b>	<b>0,4</b>	<b>2,0</b>	<b>1,0</b>	<b>0,40</b>

SF-1 - SF-1F

Diametro esterno Outer diameter D	Tolleranze diametro esterno Outer diameter tolerances D	Tolleranze spessore Thickness tolerances S <sub>B</sub>		Dimensioni smusso Chamfer dimensions S <sub>B</sub> f <sub>1</sub> f <sub>2</sub>		
≤ 10	+ 0,055 + 0,025	0,75	0 - 0,020	0,75	0,5 ± 0,3	- 0,05 - 0,30
10 < ≤ 18	+ 0,065 + 0,030	1	+ 0,005 - 0,020	1	0,6 ± 0,4	- 0,1 - 0,4
18 < ≤ 30	+ 0,075 + 0,035	1,5	+ 0,005 - 0,025	1,5	0,6 ± 0,4	- 0,1 - 0,6
30 < ≤ 50	+ 0,085 + 0,045	2	+ 0,005 - 0,030	2	1,2 ± 0,4	- 0,1 - 0,7
50 < ≤ 80	+ 0,100 + 0,055	2,5	D ≤ 80 + 0,005 - 0,040	2,5	1,8 ± 0,6	- 0,2 - 1,0
80 < ≤ 120	+ 0,120 + 0,070	2,5	80 < D ≤ 120 - 0,010 - 0,060	2,5	1,8 ± 0,6	- 0,2 - 1,0
120 < ≤ 180	+ 0,170 + 0,100	2,5	D > 120 - 0,035 - 0,085	2,5	1,8 ± 0,6	- 0,2 - 1,0
180 < ≤ 305	+ 0,255 + 0,125	2,5	D > 120 - 0,035 - 0,085	2,5	1,8 ± 0,6	- 0,2 - 1,0

Tolleranze di montaggio raccomandate:		Recommended mounting tolerances:	
<b>Albero:</b>	<b>Foro:</b>	<b>Shaft:</b>	<b>Bore:</b>
≤ 4 = h 6	≤ 4 = H 6	≤ 4 = h 6	≤ 4 = H 6
da 5 a 75 = f7	> 4 = H 7	from 5 to 75 = f7	> 4 = H 7
≥ 80 = h 8		≥ 80 = h 8	

Tolleranze di montaggio raccomandate SF-1F:		Recommended mounting tolerances SF-1F:	
<b>Albero:</b>	<b>Foro:</b>	<b>Shaft:</b>	<b>Bore:</b>
f7	≤ 4 = H 6	f7	≤ 4 = H 6
	> 4 = H 7		> 4 = H 7

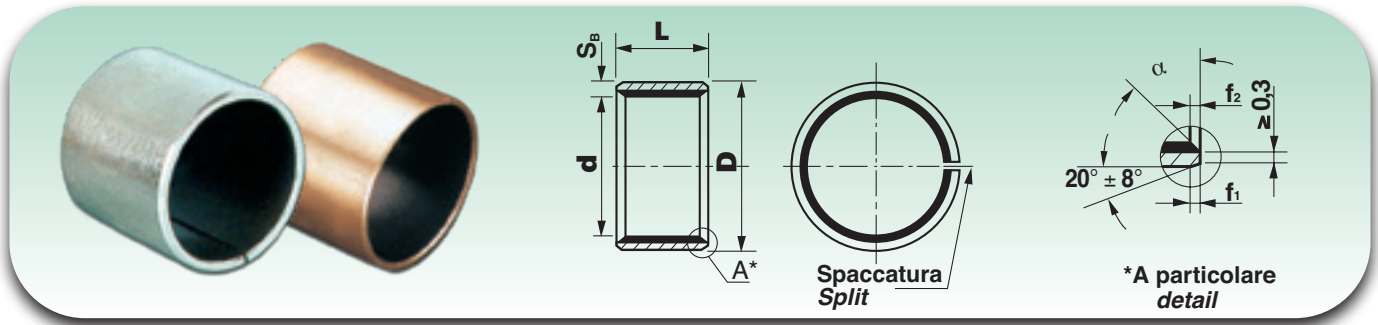

\*A particolare detail

Dimensioni (mm) Dimensions (mm)		
d	D	L <sup>±0,25</sup>
2	3,5	3
		5
3	4,5	3
		4
		5
		6
4	5,5	3
		4
		5
		6
		7
		8
		9
5	7	4
		5
		6
		7
6	8	4
		5
		6
		7
		8
		10
		12
7	9	10
		4
		5
		6
8	10	7
		8
		10
		12
		15
		16
		20
		8
10		
10	12	5
		6
		7
		8
		10
		12
		13,5
11	13	15
		20
		25
		7,5

Dimensioni (mm) Dimensions (mm)		
d	D	L <sup>±0,25</sup>
12	14	5
		6
		8
		10
		12
		15
		20
13	15	8
		10
		15
		20
		30
14	16	5
		8
		10
		12
		14
		15
		20
		25
		30
		32
15	17	6
		8
		10
		12
		15
		20
		25
16	18	5
		8
		10
		12
		15
		16
		20
		25
17	19	10
		12
		15
		17
		20
18	20	8
		9
		10
		12
		15
		16
		18
		20

Dimensioni (mm) Dimensions (mm)		
d	D	L <sup>±0,25</sup>
18	20	22
		25
		45
20	22	10
		15
		20
		22
		25
		30
		5
		10
20	23	12
		15
		20
		25
		30
21	23	20
		17
22	25	10
		12
		15
		17
		20
		25
		30
		22
24	27	14
		15
		20
		25
		28
		30
		15
		20
24	28	24
		25
		30
		5
		10
		15
		20
25	28	25
		30
		40
		50
		12
28	32	10
		12
		13
		15

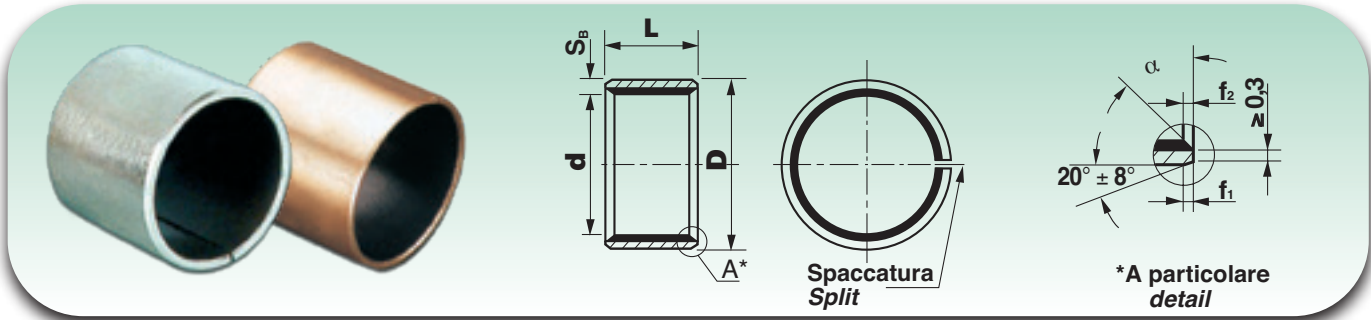

Dimensioni (mm) Dimensions (mm)		
d	D	L <sup>±0,25</sup>
28	32	20
		24
		25
		28
		30
		40
		43
		50
30	34	10
		12
		15
		20
		23
		25
		30
		32
		35
		40
32	35	14
	36	8
		15
		20
		25
		30
40		
35	39	12
		14
		15
		20
		25
		26
		30
		35
		40
		50
36	40	40
37	41	20
38	42	15
		20
		25
		30
		38
		40
40	44	12
		15
		20
		25
		30
		35
		40
		40

Dimensioni (mm) Dimensions (mm)				
d	D	L <sup>±0,25</sup>		
40	44	45		
		50		
41	45	15		
45	50	20		
		25		
		30		
		40		
		45		
		50		
		50	55	15
				20
		25		
		30		
		40		
		45		
		50		
		60		
55	60	10		
		15		
		20		
		25		
		30		
		35		
		40		
		50		
		55		
		60		
56	61	20		
60	65	20		
		25		
		30		
		35		
		40		
		50		
		55		
		60		
		70		
		80		
65	70	25		
		30		
		35		
		40		
		50		
		60		
		65		
		70		
70	75	30		
		35		
		40		
		50		
		60		
		60		

Dimensioni (mm) Dimensions (mm)				
d	D	L <sup>±0,25</sup>		
70	75	70		
		80		
75	80	30		
		40		
		50		
		60		
		70		
		75		
		80		
		90		
		80	85	25
				30
		35		
		40		
		50		
		60		
		70		
		80		
85	90	100		
		30		
		40		
		50		
		60		
		80		
		85		
		100		
		90	95	30
				40
		50		
		60		
		70		
		80		
		90		
		100		
		120		
95	100	20		
		30		
		60		
		80		
		95		
		100		
		140		
		100	105	50
		60		
		70		
		80		
		100		
		115		
105	110	60		
		80		

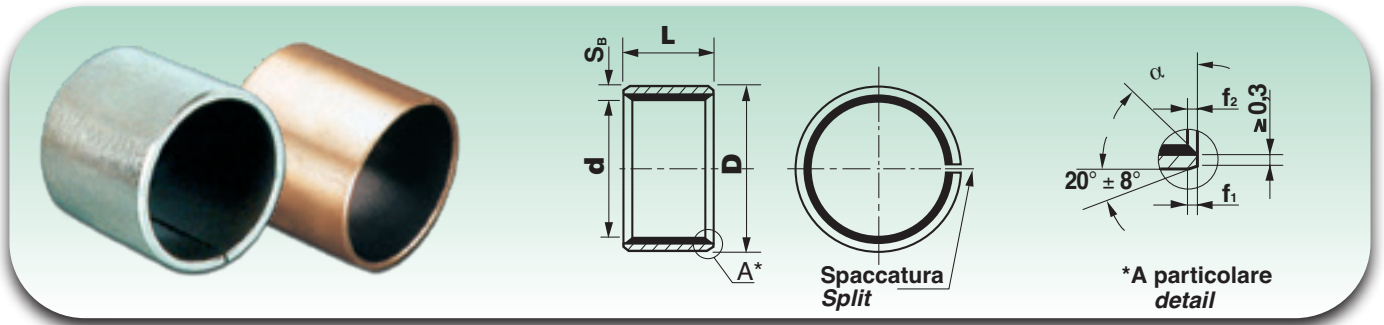

Dimensioni (mm) Dimensions (mm)		
d	D	L <sup>±0,25</sup>
105	110	100
		105
		115
110	115	50
		60
		80
		100
		115
		115
115	120	50
		60
		70
		115
120	125	40
		50
		60
		70
		80
		95
		100
		120
		180
		125
60		
100		
115		
125		
130	135	25
		50
		60
		80
		100
		130
135	140	40
		60
		70
		80
		100

Dimensioni (mm) Dimensions (mm)		
d	D	L <sup>±0,25</sup>
140	145	50
		60
		80
		90
145	150	100
		60
		100
		120
		140
		140
150	155	50
		60
		80
		100
		150
155	160	60
		100
160	165	40
		50
		60
		80
		100
		115
		160
165	170	60
		65
		100
170	175	60
		100
		100
175	180	60
		100
		60
		80
180	185	80
		100
		180
		180
190	195	60
		80
		80
		100

Dimensioni (mm) Dimensions (mm)		
d	D	L <sup>±0,25</sup>
190	195	190
		60
200	205	80
		100
		200
		200
205	210	60
		100
210	215	60
		100
215	220	60
		100
		100
220	225	50
		60
		80
		100
		100
		220
225	230	185
		60
230	235	100
		100
240	245	60
		100
		60
250	255	80
		100
		250
		80
		100
260	265	100
		260
		60
		80
280	285	100
		280
		80
		280
300	305	60
		80
		100
		300
445	450	125

**Per ordinare specificare: SF-1 + d + L**
**To order, please specify: SF-1 + d + L**

Possono essere fornite boccole a disegno per quantità.

Bushings made according drawings can be supplied if large quantities are ordered.

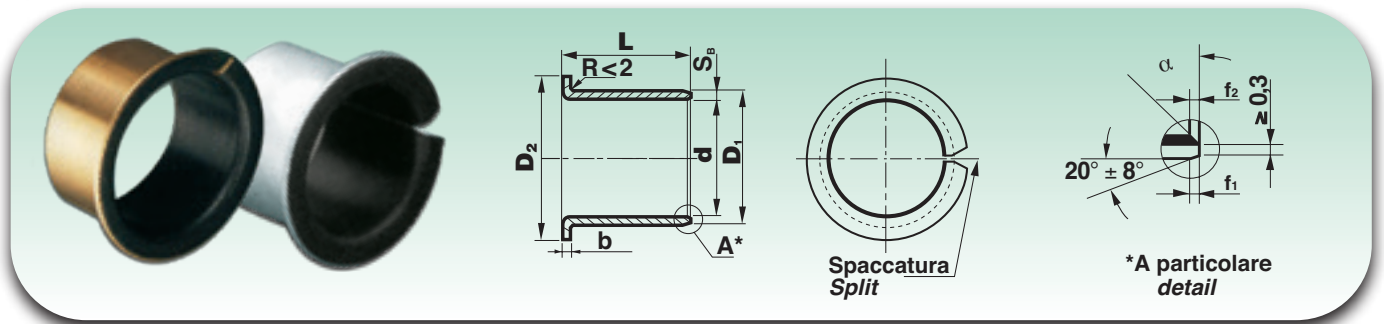

Sigla Designation	Dimensioni (mm) Dimensions (mm)								
	d	D <sub>1</sub>	D <sub>2</sub> <sup>±0,50</sup>	L <sup>±0,25</sup>	b <sup>-0,2</sup>				
F 3-4	3	4,5	7	4	0,75				
F 4-3,7	4	5,5	9	3,7	0,75				
F 4-4				4					
F 4-5				5					
F 4-6				6					
F 4-7				7					
F 4-8				8					
F 5-4	5	7	10	4	1				
F 5-5				5					
F 5-6				6					
F 5-7				7					
F 5-8				8					
F 6-4				6		8	12	4	1
F 6-7	7								
F 6-8	8								
F 6-12,7	12,7								
F 8-4	8	10	15		4			1	
F 8-5,5					5,5				
F 8-6				6					
F 8-7,5				7,5					
F 8-8				8					
F 8-9,5				9,5					
F 8-10	10								
F 10-5	10	12	18	5	1				
F 10-5,5				5,5					
F 10-7				7					
F 10-9				9					
F 10-12				12					
F 10-17				17					
F 12-7	12	14	20	7	1				
F 12-8				8					
F 12-9				9					
F 12-12				12					
F 12-15				15					
F 12-17				17					
F 14-12	14	16	22	12	1				
F 14-17				17					
F 15-9				9		1			
F 15-12	15	1							
F 15-17	17								
F 16-9	16		18	24	9	1			
F 16-11		11							
F 16-12		12							
F 16-17		17							
F 18-12	18	20	26	12	1				
F 18-17				17					
F 18-20				20					
F 18-22				22					

Sigla Designation	Dimensioni (mm) Dimensions (mm)				
	d	D <sub>1</sub>	D <sub>2</sub> <sup>±0,50</sup>	L <sup>±0,25</sup>	b <sup>-0,2</sup>
F 20-6	20	23	30	6	1,5
F 20-6,5				6,5	
F 20-7,5				7,5	
F 20-11				11	
F 20-11,5				11,5	
F 20-12				12	
F 20-15				15	
F 20-16,5				16,5	
F 20-17				17	
F 20-21,5				21,5	
F 20-22				22	
F 22-11,5				22	
F 22-15	15				
F 22-16,5	17				
F 22-20	20				
F 25-11,5	25	28	35	11,5	1,5
F 25-12				12	
F 25-16,5				16,5	
F 25-17				17	
F 25-21,5				21,5	
F 25-22				22	
F 30-16	30	34	42	16	2
F 30-26				26	
F 30-30				30	
F 32-25	32	36	43	25	2
F 35-9	35	39	47	9	2
F 35-16				16	
F 35-20				20	
F 35-26				26	
F 38-30	38	42	52	30	2
F 40-16	40	44	53	16	2
F 40-26				26	
F 40-40				40	
F 45-16	45	50	60	16	2,5
F 45-20				20	
F 45-25				25	
F 45-26				26	
F 45-30				30	
F 45-32,5				32,5	
F 45-40				40	
F 45-50				50	
F 50-20	50	55	65	20	2,5
F 50-30				30	
F 50-40				40	
F 55-30	55	60	70	30	2,5
F 55-40				40	
F 60-30	60	65	75	30	2,5
F 60-40				40	
F 60-50				50	

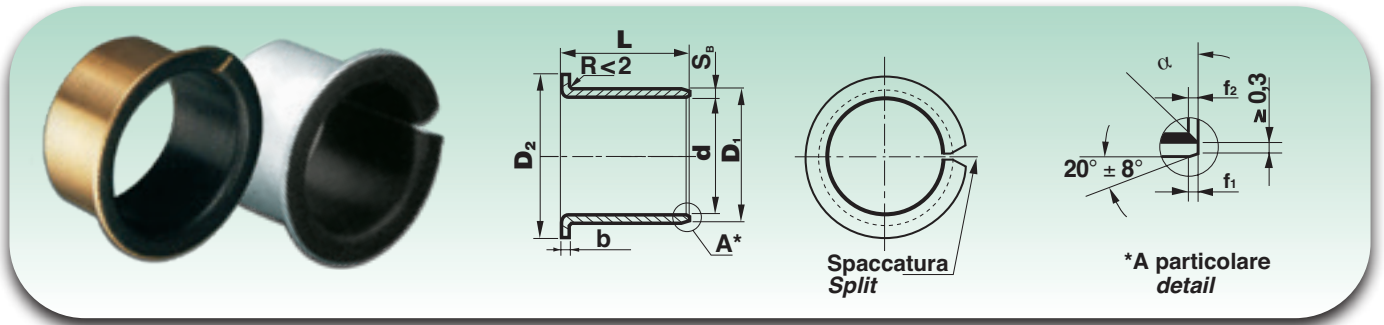

Sigla Designation	Dimensioni (mm) Dimensions (mm)				
	d	D <sub>1</sub>	D <sub>2</sub> <sup>±0,50</sup>	L <sup>±0,25</sup>	b <sup>-0,2</sup>
F 65-30	65	70	80	30	2,5
F 65-40				40	
F 70-30	70	75	85	30	2,5
F 70-40				40	
F 75-30	75	80	90	30	2,5
F 75-40				40	
F 80-30	80	85	95	30	2,5
F 80-40				40	

Sigla Designation	Dimensioni (mm) Dimensions (mm)				
	d	D <sub>1</sub>	D <sub>2</sub> <sup>±0,50</sup>	L <sup>±0,25</sup>	b <sup>-0,2</sup>
F 85-30	85	90	100	30	2,5
F 85-40				40	
F 90-30	90	95	105	30	2,5
F 90-40				40	
F 95-30	95	100	110	30	2,5
F 95-40				40	
F 120-90	120	125	140	90	2,5
-	-	-	-	-	-

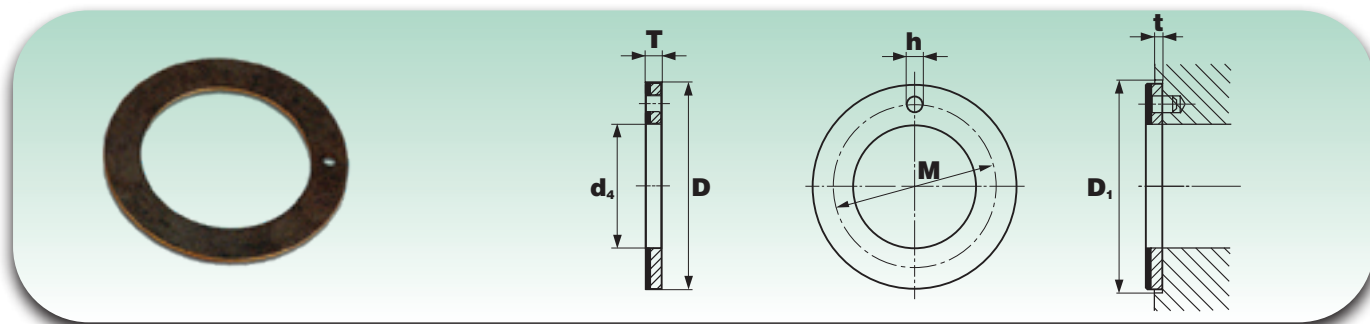

Sigla Designation	Dimensioni (mm) Dimensions (mm)				Dimensioni di montaggio (mm) Mounting dimensions (mm)		
	$d_4^{\pm 0,25}$	$D^{-0,25}$	$T^{-0,05}$	$M^{\pm 0,15}$	$h^{\begin{smallmatrix} +0,4 \\ +0,1 \end{smallmatrix}}$	$t^{\pm 0,2}$	$D_1^{+0,12}$
WC-1B 9	9	19	1	14	2	0,5	19
WC-1B 10	10	20	1,5	15	1,5	1	20
WC-1B 12	12	24	1,5	18	1,5	1	24
WC-1B 14	14	26	1,5	20	2	1	26
WC-1B 15	15	28	1	21,5	2	1	28
WC-1B 16	16	30	1,5	23	2	1	30
WC-1B 18	18	32	1,5	25	2	1	32
WC-1B 20	20	36	1,5	28	3	1	36
WC-1B 22	22	38	1,5	30	3	1	38
WC-1B 24	24	42	1,5	33	3	1	42
WC-1B 26	26	44	1,5	35	4	1	44
WC-1B 28	28	48	1,5	38	4	1	48
WC-1B 30	30	52	1,5	41	4	1	52
WC-1B 32	32	54	1,5	43	4	1	54
WC-1B 35	35	58	1,5	46,5	4	1	58
WC-1B 38	38	62	1,5	50	4	1	62
WC-1B 40	40	64	1,5	52	4	1	64
WC-1B 42	42	66	1,5	54	4	1	66
WC-1B 45	45	70	1,5	57,5	4	1	70
WC-1B 48	48	74	2	61	4	1,5	74
WC-1B 50	50	76	2	63	4	1,5	76
WC-1B 52	52	78	2	65	4	1,5	78
WC-1B 60	60	90	2	75	5	1,5	90
WC-1B 62	62	90	2	76	4	1,5	90
WC-1B 90	90	130	2	110	5	2	130

Per ordinare specificare: sigla

To order, please specify: designation

Le tolleranze riportate in questa pagina rispettano la norma ISO 6525:1983

The tolerance values given on this page comply with standard ISO 6525:1983

Consigliamo l'utilizzo di un perno o di una vite di arresto per evitare la rotazione. Il fermo deve essere incassato sotto il piano della ralla di almeno 0,25 mm.

A dowel or counter grub screw should be used to prevent rotation, but the head must be recessed at least 0,25 mm below the thrust washer surface.

Su richiesta disponibili:

• senza foro

On request, available also:

• without hole

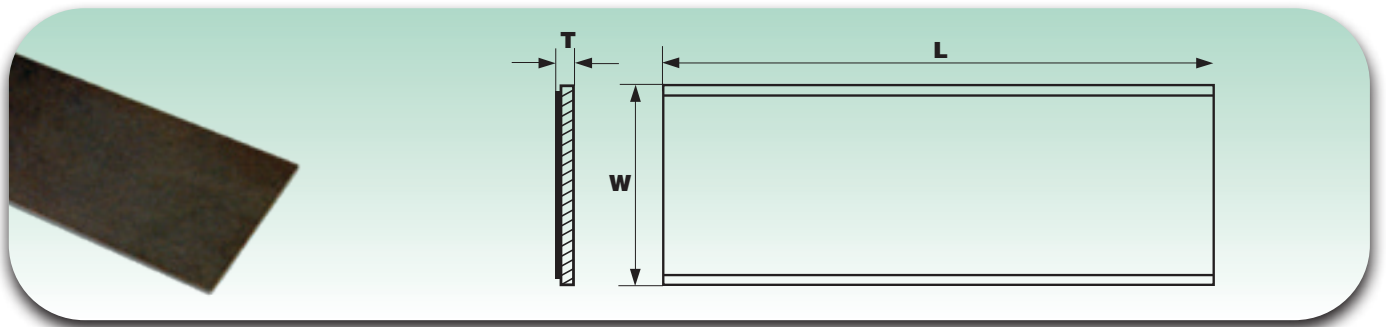

Sigla <i>Designation</i>	Dimensioni (mm) - <i>Dimensions (mm)</i>		
	Lunghezza <i>Length</i> $L_{\pm 1}$	Altezza <i>Width</i> $W_{\pm 1}$	Spessore <i>Thickness</i> $T_{-0.05}$
NSTR-S 050125	500	125	0,50
NSTR-S 075125	500	125	0,75
NSTR-S 100125	500	125	1,0
NSTR-S 150125	500	125	1,5
NSTR-S 200125	500	125	2,0
NSTR-S 250125	500	125	2,5
NSTR-S 300125	500	125	3
NSTR-S 150200	500	200	1,5
NSTR-S 200200	500	200	2,0
NSTR-S 250200	500	200	2,5
NSTR-S 300200	500	200	3,0
NSTR-S 200250	500	250	2,0
NSTR-S 250250	500	250	2,5
NSTR-S 300250	500	250	3,0

**Per ordinare specificare: sigla**

**To order, please specify: designation**

**Su richiesta disponibili:**

- con rivestimento in bronzo (NSTR-SB)
- versione 090 (NSTR 090)

**On request, available also:**

- with bronze covering (NSTR-SB)
- 090 version (NSTR 090)

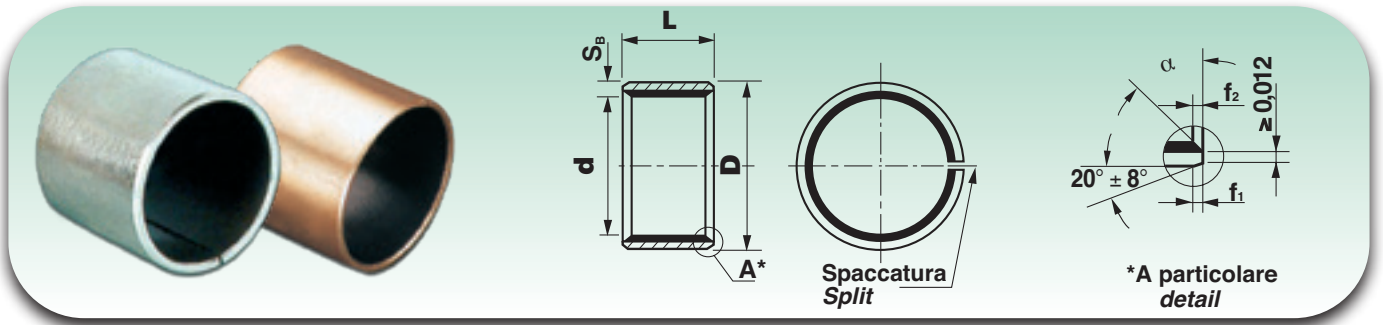

Sigla Designation	Dimensioni (pollici/mm) Dimensions (inches/mm)					
	d		D		L ±0,010"	
	inch.	mm	inch.	mm	inch.	mm
1/8 - 1/8	1/8	3,18	3/16	4,76	1/8	3,18
1/8 - 3/16					3/16	4,76
5/32 - 5/32	5/32	3,97	7/32	5,56	5/32	3,97
5/32 - 1/4					1/4	6,35
3/16 - 3/16	3/16	4,76	1/4	6,35	3/16	4,76
3/16 - 1/4					1/4	6,35
3/16 - 3/8	1/4	6,35	5/16	7,94	3/8	9,53
1/4 - 1/4					1/4	6,35
1/4 - 3/8	5/16	7,94	3/8	9,53	3/8	9,53
5/16 - 3/8					3/8	9,53
5/16 - 1/2	3/8	9,53	1/2	12,70	1/2	12,70
3/8 - 3/16					3/16	4,76
3/8 - 1/4	3/8	9,53	15/32	11,91	1/4	6,35
3/8 - 3/8					3/8	9,53
3/8 - 1/2	5/8	15,88	5/8	15,88	5/8	15,88
3/8 - 5/8					5/8	15,88
3/8 - 3/4	7/16	11,11	17/32	13,49	3/4	19,05
7/16 - 3/8					3/8	9,53
7/16 - 1/2	1/2	12,70	19/32	15,80	1/2	12,70
7/16 - 3/4					3/4	19,05
1/2 - 1/4	1/2	12,70	19/32	15,80	1/4	6,35
1/2 - 3/8					3/8	9,53
1/2 - 1/2	5/8	15,88	23/32	18,26	1/2	12,70
1/2 - 5/8					5/8	15,88
1/2 - 3/4	7/8	22,23	25/32	19,84	3/4	19,05
1/2 - 7/8					7/8	22,23
9/16 - 5/16	9/16	14,29	21/32	16,67	5/16	7,94
9/16 - 3/8					3/8	9,53
9/16 - 1/2	5/8	15,88	23/32	18,26	1/2	12,70
9/16 - 5/8					5/8	15,88
9/16 - 3/4	11/16	17,46	25/32	19,84	3/4	19,05
5/8 - 1/4					1/4	6,35
5/8 - 1/2	3/4	19,05	7/8	22,23	1/2	12,70
5/8 - 5/8					5/8	15,88
5/8 - 3/4	1 1/8	25,40	1	25,40	3/4	19,05
5/8 - 7/8					7/8	22,23
5/8 - 1	1 1/16	20,64	15/16	23,81	1	25,40
11/16 - 7/8					7/8	22,23
3/4 - 1/4	3/4	19,05	7/8	22,23	1/4	6,35
3/4 - 3/8					3/8	9,53
3/4 - 1/2	1 7/8	47,63	2 1/16	52,39	1/2	12,70
3/4 - 5/8					5/8	15,88
3/4 - 3/4	2	50,80	2 3/16	55,56	3/4	19,05
3/4 - 1					1	25,40
13/16 - 3/4	7/8	22,23	1	25,40	3/4	19,05
13/16 - 1 1/8					1 1/8	28,58
7/8 - 1/4	1 1/4	31,75	1 13/32	35,72	1/4	6,35

Sigla Designation	Dimensioni (pollici/mm) Dimensions (inches/mm)					
	d		D		L ±0,010"	
	inch.	mm	inch.	mm	inch.	mm
7/8 - 3/8	7/8	22,23	1	25,40	3/8	9,53
7/8 - 3/4					3/4	19,05
7/8 - 7/8					7/8	22,23
7/8 - 1					1	25,40
7/8 - 1 1/4					1 1/4	31,75
1 - 3/8	1	25,40	1 1/8	28,58	3/8	9,53
1 - 1/2					1/2	12,70
1 - 3/4					3/4	19,05
1 - 1					1	25,40
1 - 1 1/4					1 1/4	31,75
1 - 1 1/2	1 1/8	28,58	1 9/32	32,54	1 1/2	38,10
1 1/8 - 1 1/8					3/8	9,53
1 1/8 - 5/8					5/8	15,88
1 1/8 - 3/4					3/4	19,05
1 1/8 - 1					1	25,40
1 1/4 - 3/8	1 1/4	31,75	1 13/32	35,72	3/8	9,53
1 1/4 - 1/2					1/2	12,70
1 1/4 - 3/4					3/4	19,05
1 1/4 - 7/8					7/8	22,23
1 1/4 - 1					1	25,40
1 1/4 - 1 1/4	1 3/8	34,93	1 17/32	38,89	1 1/4	31,75
1 1/4 - 1 3/4					1 3/4	44,45
1 3/8 - 5/8					5/8	15,88
1 3/8 - 3/4					3/4	19,05
1 3/8 - 1					1	25,40
1 3/8 - 1 3/8	1 1/2	38,10	1 17/32	38,89	1 3/8	34,93
1 3/8 - 1 1/2					1 1/2	38,10
1 1/2 - 1/2					1/2	12,70
1 1/2 - 1					1	25,40
1 1/2 - 1 1/8					1 1/8	28,58
1 1/2 - 1 1/4	1 5/8	41,28	1 25/32	45,24	1 1/4	31,75
1 1/2 - 1 1/2					1 1/2	38,10
1 1/2 - 2					2	50,80
1 5/8 - 1					1	25,40
1 5/8 - 1 1/2					1 1/2	38,10
1 3/4 - 1	1 3/4	44,45	1 15/16	49,21	1 3/4	44,45
1 3/4 - 1 1/2					1 1/2	38,10
1 3/4 - 1 3/4					1 3/4	44,45
1 3/4 - 2					2	50,80
1 7/8 - 3/4					3/4	19,05
1 7/8 - 1	1 7/8	47,63	2 1/16	52,39	1	25,40
1 7/8 - 1 7/8					1 7/8	47,63
1 7/8 - 2 1/4					2 1/4	57,15
2 - 1/2					1/2	12,70
2 - 1					1	25,40
2 - 1 1/2	2	50,80	2 3/16	55,56	1 1/2	38,10
2 - 1 3/4					1 3/4	44,45

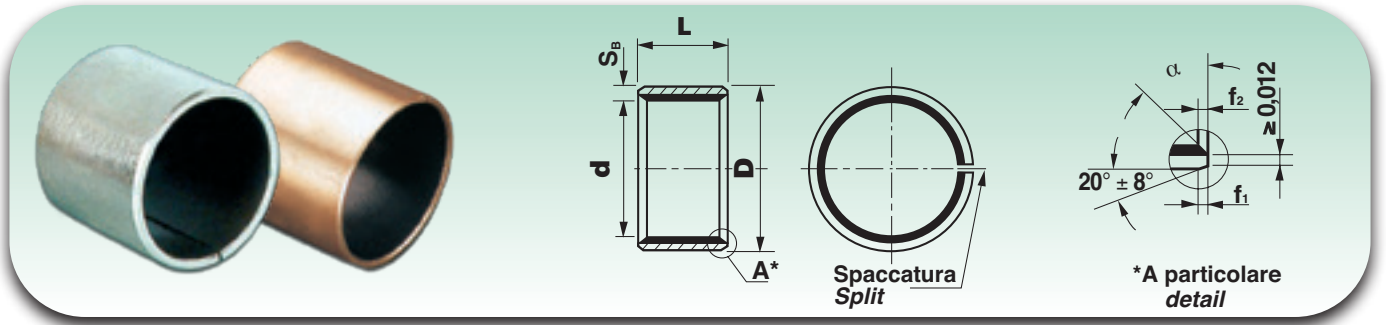

Sigla Designation	Dimensioni (pollici/mm) Dimensions (inches/mm)					
	d		D		L ±0,010"	
	inch.	mm	inch.	mm	inch.	mm
2 - 2	2	50,80	2 <sup>3</sup> / <sub>16</sub>	55,56	2	50,80
2 - 2 1/2					2 1/2	63,50
2 1/8 - 3	2 1/8	53,98	2 <sup>5</sup> / <sub>16</sub>	58,74	3	76,20
2 1/4 - 1 3/4	2 1/4	57,15	2 <sup>7</sup> / <sub>16</sub>	61,91	1 3/4	44,45
2 1/4 - 2					2	50,80
2 1/4 - 2 1/4					2 1/4	57,15
2 1/4 - 2 1/2					2 1/2	63,50
2 1/4 - 3					3	76,20
2 1/4 - 3 1/2					3 1/2	88,90
2 1/4 - 3 3/4					3 3/4	95,25
2 1/4 - 4					4	101,60
2 1/4 - 4 1/4	4 1/4	107,95				
2 1/2 - 1	2 1/2	63,50	2 <sup>11</sup> / <sub>16</sub>	68,26	1	25,40
2 1/2 - 1 5/8					1 5/8	41,28
2 1/2 - 2					2	50,80
2 1/2 - 2 1/2					2 1/2	63,50
2 1/2 - 3					3	76,20
2 1/2 - 3 1/2					3 1/2	88,90
2 1/2 - 3 3/4					3 3/4	95,25
2 1/2 - 4					4	101,60
2 1/2 - 4 1/2	4 1/2	114,30				
2 1/2 - 4 3/4	4 3/4	120,65				
2 3/4 - 2	2 3/4	69,85	2 <sup>15</sup> / <sub>16</sub>	74,61	2	50,80
2 3/4 - 2 1/4					2 1/4	57,15
2 3/4 - 2 1/2					2 1/2	63,50
2 3/4 - 3					3	76,20
2 3/4 - 3 1/2					3 1/2	88,90
2 3/4 - 3 3/4					3 3/4	95,25
2 3/4 - 4					4	101,60
2 3/4 - 4 1/2					4 1/2	114,30
2 3/4 - 4 3/4	4 3/4	120,65				
2 3/4 - 5	5	127,00				
2 7/8 - 2	2 7/8	73,03	3 <sup>1</sup> / <sub>16</sub>	77,79	2	50,80
2 7/8 - 2 1/4					2 1/4	57,15
2 7/8 - 2 1/2					2 1/2	63,50
2 7/8 - 3					3	76,20
2 7/8 - 3 1/2					3 1/2	88,90
2 7/8 - 3 3/4					3 3/4	95,25
2 7/8 - 4					4	101,60
2 7/8 - 4 1/2					4 1/2	114,30
2 7/8 - 4 3/4	4 3/4	120,65				
2 7/8 - 5	5	127,00				
3 - 2	3	76,20	3 <sup>3</sup> / <sub>16</sub>	80,96	2	50,80
3 - 2 1/4					2 1/4	57,15
3 - 2 1/2					2 1/2	63,50
3 - 3					3	76,20
3 - 3 1/2					3 1/2	88,90

Sigla Designation	Dimensioni (pollici/mm) Dimensions (inches/mm)					
	d		D		L ±0,010"	
	inch.	mm	inch.	mm	inch.	mm
3 - 3 3/4	3	76,20	3 <sup>3</sup> / <sub>16</sub>	80,96	3 3/4	95,25
3 - 4					4	101,60
3 - 4 1/2					4 1/2	114,30
3 - 4 3/4					4 3/4	120,65
3 - 5					5	127,00
3 1/4 - 2	3 1/4	82,55	3 <sup>7</sup> / <sub>16</sub>	87,31	2	50,80
3 1/4 - 2 3/8					2 3/8	60,33
3 1/4 - 2 1/2					2 1/2	63,50
3 1/4 - 3					3	76,20
3 1/4 - 3 1/2					3 1/2	88,90
3 1/4 - 3 3/4					3 3/4	95,25
3 1/4 - 4					4	101,60
3 1/4 - 4 1/2					4 1/2	114,30
3 1/2 - 2	3 1/2	88,90	3 <sup>11</sup> / <sub>16</sub>	93,66	2	50,80
3 1/2 - 2 3/8					2 3/8	60,33
3 1/2 - 2 1/2					2 1/2	63,50
3 1/2 - 3					3	76,20
3 1/2 - 3 1/2					3 1/2	88,90
3 1/2 - 3 3/4					3 3/4	95,25
3 1/2 - 4					4	101,60
3 1/2 - 4 1/2					4 1/2	114,30
3 1/2 - 4 3/4	4 3/4	120,65				
3 1/2 - 5	5	127,00				
3 5/8 - 2	3 5/8	92,08	3 <sup>13</sup> / <sub>16</sub>	96,84	2	50,80
3 5/8 - 2 1/4					2 1/4	57,15
3 5/8 - 2 1/2					2 1/2	63,50
3 5/8 - 3					3	76,20
3 5/8 - 3 1/2					3 1/2	88,90
3 5/8 - 3 3/4					3 3/4	95,25
3 5/8 - 4					4	101,60
3 5/8 - 4 1/2					4 1/2	114,30
3 5/8 - 4 3/4	4 3/4	120,65				
3 5/8 - 5	5	127,00				
3 3/4 - 2	3 3/4	95,25	3 <sup>15</sup> / <sub>16</sub>	100,01	2	50,80
3 3/4 - 2 1/4					2 1/4	57,15
3 3/4 - 2 1/2					2 1/2	63,50
3 3/4 - 3					3	76,20
3 3/4 - 3 1/2					3 1/2	88,90
3 3/4 - 3 3/4					3 3/4	95,25
3 3/4 - 4					4	101,60
3 3/4 - 4 1/2					4 1/2	114,30
3 3/4 - 4 3/4	4 3/4	120,65				
3 3/4 - 5	5	127,00				
4 - 2	4	101,60	3 <sup>3</sup> / <sub>16</sub>	80,96	2	50,80
4 - 2 1/4					2 1/4	57,15

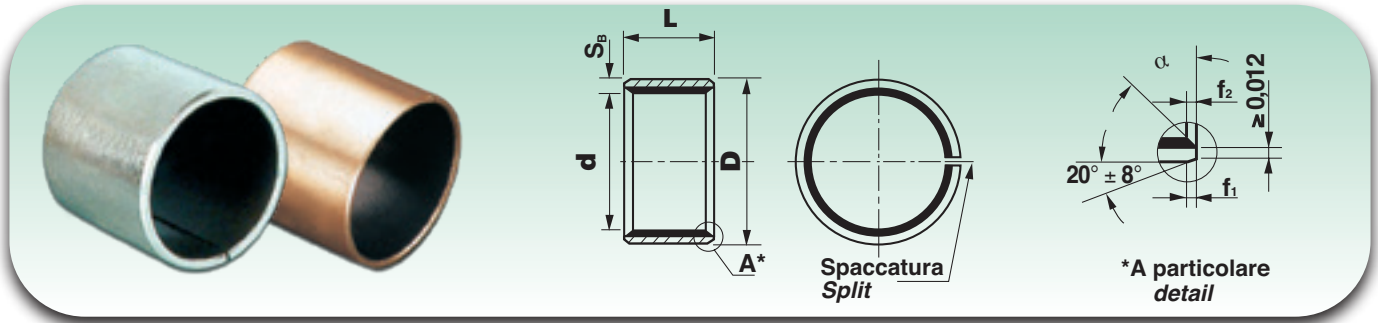

Sigla Designation	Dimensioni (pollici/mm) Dimensions (inches/mm)									
	d		D		L ±0,010"					
	inch.	mm	inch.	mm	inch.	mm				
4-2 1/2	4	101,60	3 3/16	80,96	1 1/2	63,50				
4-3					3	76,20				
4-3 1/2					3 1/2	88,90				
4-3 3/4					3 3/4	95,25				
4-4					4	101,60				
4-4 1/2					4 1/2	114,30				
4-4 3/4					4 3/4	120,65				
4-5					5	127,00				
4 1/4-2					4 1/4	107,95	4 7/16	112,71	2	50,80
4 1/4-2 1/4									2 1/4	57,15
4 1/4-2 1/2	2 1/2	63,50								
4 1/4-3	3	76,20								
4 1/4-3 1/2	3 1/2	88,90								
4 1/4-3 3/4	3 3/4	95,25								
4 1/4-4	4	101,60								
4 1/4-4 1/2	4 1/2	114,30								
4 1/4-4 3/4	4 3/4	120,65								
4 1/4-5	5	127,00								
4 3/8-2	4 3/8	111,13	4 9/16	115,89	2	50,80				
4 3/8-2 1/4					2 1/4	57,15				
4 3/8-2 1/2					2 1/2	63,50				
4 3/8-3					3	76,20				
4 3/8-3 1/2					3 1/2	88,90				
4 3/8-3 3/4					3 3/4	95,25				
4 3/8-4					4	101,60				
4 3/8-4 1/2					4 1/2	114,30				
4 3/8-4 3/4					4 3/4	120,65				
4 3/8-5					5	127,00				
4 1/2-2	4 1/2	114,30	4 11/16	119,06	2	50,80				
4 1/2-2 1/4					2 1/4	57,15				
4 1/2-2 1/2					2 1/2	63,50				
4 1/2-3					3	76,20				
4 1/2-3 1/2					3 1/2	88,90				
4 1/2-3 3/4					3 3/4	95,25				
4 1/2-4					4	101,60				
4 1/2-4 1/2					4 1/2	114,30				
4 1/2-4 3/4					4 3/4	120,65				
4 1/2-5					5	127,00				
4 3/4-2	4 3/4	120,65	4 15/16	125,41	2	50,80				
4 3/4-2 1/4					2 1/4	57,15				
4 3/4-2 1/2					2 1/2	63,50				
4 3/4-3					3	76,20				
4 3/4-3 1/2					3 1/2	88,90				
4 3/4-3 3/4					3 3/4	95,25				
4 3/4-4					4	101,60				
4 3/4-4 1/2					4 1/2	114,30				
4 3/4-4 3/4					4 3/4	120,65				
4 3/4-5					5	127,00				

Sigla Designation	Dimensioni (pollici/mm) Dimensions (inches/mm)					
	d		D		L ±0,010"	
	inch.	mm	inch.	mm	inch.	mm
4 3/4-5	4 3/4	120,65	4 15/16	125,41	5	127,00
5-2					2	50,80
5-2 1/4					2 1/4	57,17
5-2 1/2					2 1/2	63,50
5-3					3	76,20
5-3 1/2					3 1/2	88,90
5-3 3/4					3 3/4	95,25
5-4					4	101,60
5-4 1/2					4 1/2	114,30
5-4 3/4					4 3/4	120,65
5-5	5	127,00				
5 1/4-2	5 1/4	133,35	5 7/16	138,11	2	50,80
5 1/4-2 1/4					2 1/4	57,15
5 1/4-2 1/2					2 1/2	63,50
5 1/4-3					3	76,20
5 1/4-3 1/2					3 1/2	88,90
5 1/4-3 3/4					3 3/4	95,25
5 1/4-4					4	101,60
5 1/4-4 1/2					4 1/2	114,30
5 1/4-4 3/4					4 3/4	120,65
5 1/4-5					5	127,00
5 1/2-2	5 1/2	139,70	5 11/16	144,46	2	50,80
5 1/2-2 1/4					2 1/4	57,15
5 1/2-2 1/2					2 1/2	63,50
5 1/2-3					3	76,20
5 1/2-3 1/2					3 1/2	88,90
5 1/2-3 3/4					3 3/4	95,25
5 1/2-4					4	101,60
5 1/2-4 1/2					4 1/2	114,30
5 1/2-4 3/4					4 3/4	120,65
5 1/2-5					5	127,00
5 3/4-2	5 3/4	146,05	5 15/16	150,81	2	50,80
5 3/4-2 1/4					2 1/4	57,15
5 3/4-2 1/2					2 1/2	63,50
5 3/4-3					3	76,20
5 3/4-3 1/2					3 1/2	88,90
5 3/4-3 3/4					3 3/4	95,25
5 3/4-4					4	101,60
5 3/4-4 1/2					4 1/2	114,30
5 3/4-4 3/4					4 3/4	120,65
5 3/4-5					5	127,00
6-2	6	152,40	6 3/16	157,16	2	50,80
6-2 1/4					2 1/4	57,15
6-2 1/2					2 1/2	63,50
6-3					3	76,20
6-3 1/2					3 1/2	88,90
6-3 3/4					3 3/4	95,25

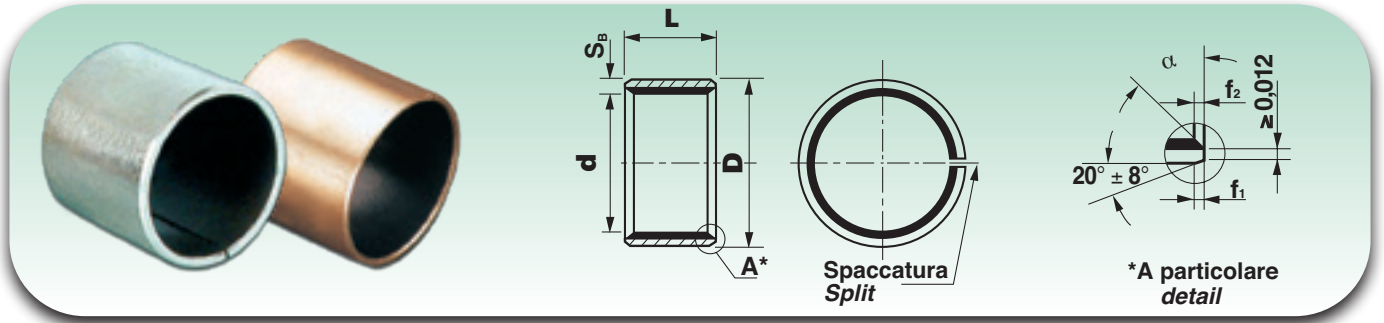

Sigla Designation	Dimensioni (pollici/mm) Dimensions (inches/mm)									
	d		D		L ±0,010"					
	inch.	mm	inch.	mm	inch.	mm				
6 - 4	6	152,40	6 <sup>3/16</sup>	157,16	4	101,60				
6 - 4 1/2					4 1/2	114,30				
6 - 14 3/4					4 3/4	120,65				
6 - 5					5	127,00				
6 1/4 - 2	6 1/4	57,15	6 7/16	163,51	2	50,80				
6 1/4 - 2 1/4					2 1/4	57,15				
6 1/4 - 2 1/2					2 1/2	63,50				
6 1/4 - 3					3	76,20				
6 1/4 - 3 1/2					3 1/2	88,90				
6 1/4 - 3 3/4					3 3/4	95,25				
6 1/4 - 4					4	101,60				
6 1/4 - 4 1/2					4 1/2	114,30				
6 1/4 - 4 3/4					4 3/4	120,65				
6 1/4 - 5					5	127,00				
6 1/2 - 2					6 1/2	165,10	6 11/16	169,86	2	50,80
6 1/2 - 2 1/4									2 1/4	57,15
6 1/2 - 2 1/2									2 1/2	63,50
6 1/2 - 3									3	76,20
6 1/2 - 3 1/2	3 1/2	88,90								
6 1/2 - 3 3/4	3 3/4	95,25								
6 1/2 - 4	4	101,60								
6 1/2 - 4 1/2	4 1/2	114,30								

Sigla Designation	Dimensioni (pollici/mm) Dimensions (inches/mm)									
	d		D		L ±0,010"					
	inch.	mm	inch.	mm	inch.	mm				
6 1/2 - 4 3/4	6 1/2	165,10	6 11/16	169,86	4 3/4	120,65				
6 1/2 - 5					5	127,00				
6 3/4 - 2	6 3/4	171,45	6 15/16	176,21	2	50,80				
6 3/4 - 2 1/4					2 1/4	57,15				
6 3/4 - 2 1/2					2 1/2	63,50				
6 3/4 - 3					3	76,20				
6 3/4 - 3 1/2					3 1/2	88,90				
6 3/4 - 3 3/4					3 3/4	95,25				
6 3/4 - 4					4	101,60				
6 3/4 - 4 1/2					4 1/2	114,30				
6 3/4 - 4 3/4					4 3/4	120,65				
6 3/4 - 5					5	127,00				
7 - 2					7	177,80	7 3/16	182,56	2	50,80
7 - 2 1/4									2 1/4	57,15
7 - 2 1/2									2 1/2	63,50
7 - 3									3	76,20
7 - 3 1/2	3 1/2	88,90								
7 - 3 3/4	3 3/4	95,25								
7 - 4	4	101,60								
7 - 4 1/2	4 1/2	114,30								
7 - 4 3/4	4 3/4	120,65								
7 - 5	5	127,00								

Per ordinare specificare: SF-1 + sigla

To order, please specify: SF-1 + designation

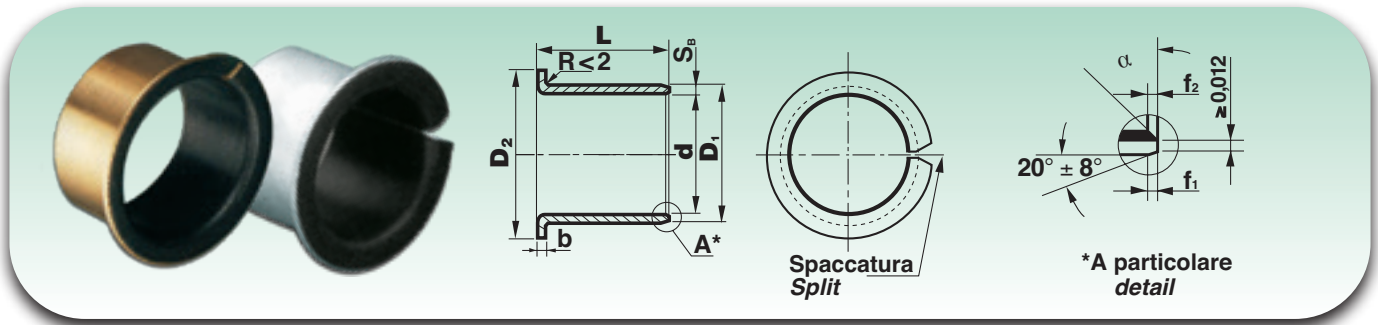

Sigla Designation	Dimensioni (pollici/mm) Dimensions (inches/mm)							
	d		D <sub>1</sub>		D <sub>2</sub> ±0,020"		L ±0,010"	
	inch.	mm	inch.	mm	inch.	mm	inch.	mm
F 3/8-1/4	3/8	9,53	15/32	11,91	11/16	17,46	1/4	6,35
F 3/8-3/8							3/8	9,53
F 3/8-1/2							1/2	12,70
F 3/8-1/2							3/4	19,05
F 1/2-1/4	1/2	12,70	19/32	15,08	13/16	20,64	1/4	6,35
F 1/2-3/8							3/8	9,53
F 1/2-1/2							1/2	12,70
F 1/2-3/4							3/4	19,05
F 5/8-3/8	5/8	15,88	23/32	18,26	15/16	23,81	3/8	9,53
F 5/8-1/2							1/2	12,70
F 5/8-5/8							5/8	15,88
F 5/8-3/4							3/4	19,05
F 3/4-3/8	3/4	19,05	7/8	22,23	1 1/8	28,58	3/8	9,53
F 3/4-1/2							1/2	12,70
F 3/4-3/4							3/4	19,05
F 3/4-1							1	25,40
F 7/8-1/2	7/8	22,23	1	25,40	1 1/4	31,75	1/2	12,70
F 7/8-3/4							3/4	19,05
F 7/8-1							1	25,40
F 7/8-1 1/4							1 1/4	31,75
F 1-1/2	1	25,40	1 1/8	28,58	1 3/8	34,93	1/2	12,70
F 1-3/4							3/4	19,05
F 1-1							1	25,40
F 1-1 1/4							1 1/4	31,75
F 1 1/4-1	1 1/4	31,75	1 13/32	35,72	1 3/4	44,45	1	25,40
F 1 1/4-1 1/4							1 1/4	31,75
F 1 1/4-1 1/2							1 1/2	38,10
F 1 1/2-1							1	25,40
F 1 1/2-1 1/2	1 1/2	38,10	1 21/32	42,07	2	50,80	1 1/2	38,10
F 1 1/2-1 1/2							1 1/2	38,10
F 1 1/2-2							2	50,80
F 1 3/4-1							1	25,40
F 1 3/4-1 1/2	1 3/4	44,45	1 15/16	49,21	2 3/8	60,33	1 1/2	38,10
F 1 3/4-2							2	50,80

Per ordinare specificare: SF-1 + sigla

To order, please specify: SF-1 + designation

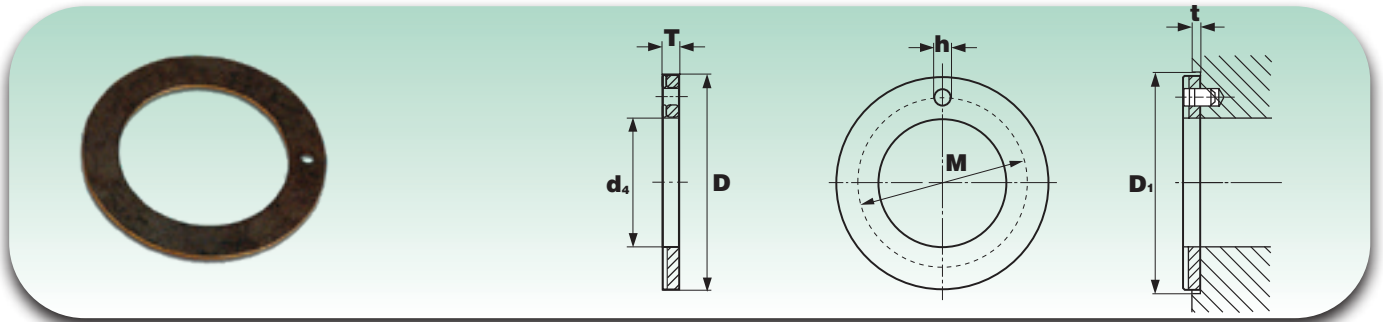

Sigla Designation	Dimensioni (pollici/mm) Dimensions (inches/mm)								Dimensioni di montaggio (pollici/mm) Mounting dimensions (inches/mm)					
	$d_4^{+0,010''}$		$D^{-0,010''}$		$T^{+0,0020''}$		$M^{-0,010''}$		$h^{+0,010''}$		$t^{\pm 0,010''}$		$D_1^{+0,010''}$	
	inch.	mm	inch.	mm	inch.	mm	inch.	mm	inch.	mm	inch.	mm	inch.	mm
WC-1 0500	0,500	12,70	0,875	22,23	0,061	1,549	0,692	17,58	0,067	1,70	0,04	1,02	0,875	22,23
WC-1 0562	0,562	14,27	1,000	25,40	0,061	1,549	0,786	19,96	0,067	1,70	0,04	1,02	1,000	25,40
WC-1 0625	0,625	15,88	1,125	28,58	0,061	1,549	0,880	22,35	0,099	2,51	0,04	1,02	1,125	28,58
WC-1 0687	0,687	17,45	1,187	30,15	0,061	1,549	0,942	23,93	0,099	2,51	0,04	1,02	1,187	30,15
WC-1 0750	0,750	19,05	1,250	31,75	0,061	1,549	1,005	25,53	0,099	2,51	0,04	1,02	1,250	31,75
WC-1 0812	0,812	20,62	1,375	34,93	0,061	1,549	1,009	27,91	0,099	2,51	0,04	1,02	1,375	34,93
WC-1 0875	0,875	22,23	1,500	38,10	0,061	1,549	1,192	30,28	0,130	3,30	0,04	1,02	1,500	38,10
WC-1 0937	0,937	23,80	1,625	41,28	0,061	1,549	1,286	32,66	0,130	3,30	0,04	1,02	1,625	41,28
WC-1 1000	1,000	25,40	1,750	44,45	0,061	1,549	1,380	35,05	0,130	3,30	0,04	1,02	1,750	44,45
WC-1 1125	1,125	28,58	2,000	50,80	0,061	1,549	1,567	39,80	0,161	4,09	0,04	1,02	2,000	50,80
WC-1 1250	1,250	31,75	2,125	53,98	0,061	1,549	1,692	42,98	0,161	4,09	0,04	1,02	2,125	53,98
WC-1 1375	1,375	34,93	2,250	57,15	0,061	1,549	1,817	46,15	0,161	4,09	0,04	1,02	2,250	57,15
WC-1 1500	1,500	38,10	2,500	63,50	0,061	1,549	2,005	50,93	0,192	4,88	0,04	1,02	2,500	63,50
WC-1 1625	1,625	41,28	2,625	66,68	0,061	1,549	2,130	54,10	0,192	4,88	0,04	1,02	2,625	66,68
WC-1 1750	1,750	44,45	2,750	69,85	0,061	1,549	2,255	52,28	0,192	4,88	0,04	1,02	2,750	69,85
WC-1 2000	2,000	50,80	3,000	76,20	0,091	2,311	2,505	63,63	0,192	4,88	0,07	1,78	3,000	76,20
WC-1 2125	2,125	53,98	3,125	79,38	0,091	2,311	2,630	66,80	0,192	4,88	0,07	1,78	3,125	79,38
WC-1 2250	2,250	57,15	3,250	82,55	0,091	2,311	2,755	69,98	0,192	4,88	0,07	1,78	3,250	82,55

**Per ordinare specificare: sigla**
**To order, please specify: designation**

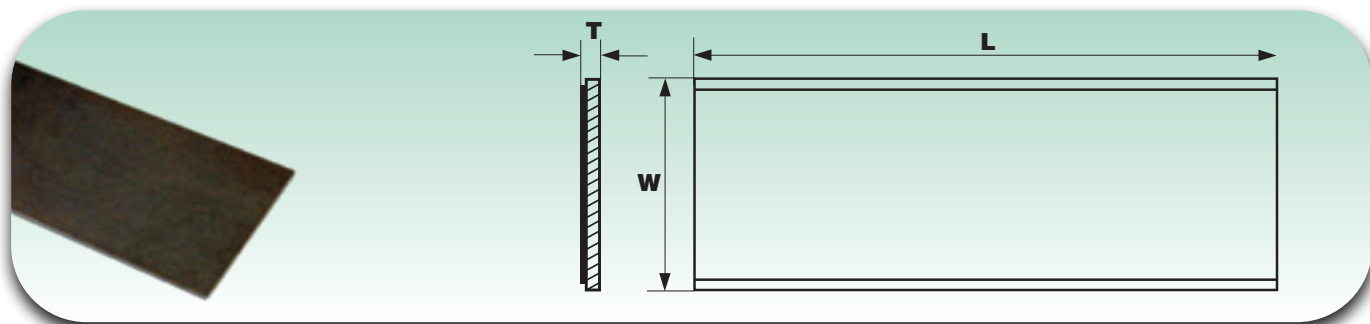

Sigla Designation	Dimensioni (pollici/mm) - Dimensions (inches/mm)					
	Lunghezza Length L +0,2"		Altezza Width W +0,1"		Spessore Thickness T -0,05"	
	inch.	mm	inch.	mm	inch.	mm
NSTR-S 00293-275	19,69	500,13	2,75	69,85	0,0293 <sup>0</sup> <sub>-0,0016</sub>	0,74 <sup>0</sup> <sub>-0,0406</sub>
NSTR-S 00447-400	19,69	500,13	4,00	101,60	0,0447 <sup>0</sup> <sub>-0,0016</sub>	1,14 <sup>0</sup> <sub>-0,0406</sub>
NSTR-S 00602-400	19,69	500,13	4,00	101,60	0,0602 <sup>0</sup> <sub>-0,0016</sub>	1,53 <sup>0</sup> <sub>-0,0406</sub>
NSTR-S 00756-400	19,69	500,13	4,00	101,60	0,0756 <sup>0</sup> <sub>-0,0016</sub>	1,92 <sup>0</sup> <sub>-0,0406</sub>
NSTR-S 00913-400	19,69	500,13	4,00	101,60	0,0913 <sup>0</sup> <sub>-0,0016</sub>	2,32 <sup>0</sup> <sub>-0,0406</sub>
NSTR-S 01210-400	19,69	500,13	4,00	101,60	0,1210 <sup>0</sup> <sub>-0,0020</sub>	3,07 <sup>0</sup> <sub>-0,0508</sub>

Per ordinare specificare: sigla

To order, please specify: designation

**Su richiesta disponibili:**

- con rivestimento in bronzo (NSTR-SB)
- versione 090 (NSTR 090)

**On request, available also:**

- with bronze covering (NSTR-SB)
- 090 version (NSTR 090)

